

SERVICE MANUAL





Model:

PDP4210EA1

Safety Precaution
Technical Specifications
Block Diagram
Circuit Diagram
Basic Operations & Circuit Description
Main IC Information
Panel Information
Spare Part List
Exploded View
If you forget your V-Chip Password
Software Upgrade

This manual is the latest at the time of printing, and does not include the modification which may be made after the printing, by the constant improvement of product.

Safety Precaution

| | |
|--------------------------------------------------------------------------------------------------------------------------------------------------------------------------------------------------------------------------------------------------------------------------------------------------------------------------------------------------------------------------------------------------------------------------------------------------------------------------------------------------------------|----------------------------------------------------------------------------------------------------------------------------------------------------------------------------------------------------------------------------------------------------------------------------------------------------------------------------------------------------------------------------|
|  <div style="border: 1px solid black; padding: 5px; text-align: center;">CAUTION RISK OF ELECTRIC SHOCK DO NOT OPEN</div>  <p>CAUTION: TO REDUCE THE RISK OF ELECTRIC SHOCK, DO NOT REMOVE COVER (OR BACK). NO USER-SERVICEABLE PARTS INSIDE. REFER SERVICING TO QUALIFIED SERVICE PERSONNEL ONLY.</p> |  <p>The lightning flash with arrowhead symbol, within an equilateral triangle, is intended to alert the user to the presence of uninsulated "dangerous voltage" within the product's enclosure that may be of sufficient magnitude to constitute a risk of electric shock to persons.</p> |
| |  <p>The exclamation point within an equilateral triangle is intended to alert the user to the presence of important operating and maintenance (servicing) instructions in the literature accompanying the appliance.</p> |

PRECAUTIONS DURING SERVICING

1. In addition to safety, other parts and assemblies are specified for conformance with such regulations as those applying to spurious radiation. These must also be replaced only with specified replacements.
Examples: RF converters, tuner units, antenna selection switches, RF cables, noise-blocking capacitors, noise-blocking filters, etc.
2. Use specified internal Wiring. Note especially:
 - 1) Wires covered with PVC tubing
 - 2) Double insulated wires
 - 3) High voltage leads
3. Use specified insulating materials for hazardous live parts. Note especially:
 - 1) Insulating Tape
 - 2) PVC tubing
 - 3) Spacers (insulating barriers)
 - 4) Insulating sheets for transistors
 - 5) Plastic screws for fixing micro switches
4. When replacing AC primary side components (transformers, power cords, noise blocking capacitors, etc.), wrap ends of wires securely about the terminals before soldering.

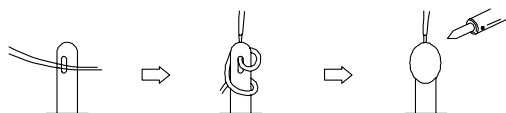

5. Make sure that wires do not contact heat generating parts (heat sinks, oxide metal film resistors, fusible resistors, etc.)
6. Check if replaced wires do not contact sharply edged or pointed parts.
7. Make sure that foreign objects (screws, solder droplets, etc.) do not remain inside the set.

MAKE YOUR CONTRIBUTION TO PROTECT THE ENVIRONMENT

Used batteries with the ISO symbol



for recycling as well as small accumulators (rechargeable batteries), mini-batteries (cells) and starter batteries should not be thrown into the garbage can.

Please leave them at an appropriate depot.

WARNING:

Before servicing this TV receiver, read the **SAFETY INSTRUCTION** and **PRODUCT SAFETY NOTICE**.

SAFETY INSTRUCTION

The service should not be attempted by anyone unfamiliar with the necessary instructions on this apparatus. The following are the necessary instructions to be observed before servicing.

1. An isolation transformer should be connected in the power line between the receiver and the AC line when a service is performed on the primary of the converter transformer of the set.
2. Comply with all caution and safety related provided on the back of the cabinet, inside the cabinet, on the chassis or picture tube.
3. To avoid a shock hazard, always discharge the picture tube's anode to the chassis ground before removing the anode cap.
4. Completely discharge the high potential voltage of the picture tube before handling. The picture tube is a vacuum and if broken, the glass will explode.

5. When replacing a MAIN PCB in the cabinet, always be certain that all protective are installed properly such as control knobs, adjustment covers or shields, barriers, isolation resistor networks etc.
6. When servicing is required, observe the original lead dressing. Extra precaution should be given to assure correct lead dressing in the high voltage area.
7. Keep wires away from high voltage or high temperature components.
8. Before returning the set to the customer, always perform an AC leakage current check on the exposed metallic parts of the cabinet, such as antennas, terminals, screwheads, metal overlay, control shafts, etc., to be sure the set is safe to operate without danger of electrical shock. Plug the AC line cord directly to the AC outlet (do not use a line isolation transformer during this check). Use an AC voltmeter having 5K ohms volt sensitivity or more in the following manner.
Connect a 1.5K ohm 10 watt resistor paralleled by a 0.15 μ F AC type capacitor, between a good earth ground (water pipe, conductor etc.,) and the exposed metallic parts, one at a time. Measure the AC voltage across the combination of the 1.5K ohm resistor and 0.15 μ F capacitor. Reverse the AC plug at the AC outlet and repeat the AC voltage measurements for each exposed metallic part.

The measured voltage must not exceed 0.3V RMS.

This corresponds to 0.5mA AC. Any value exceeding this limit constitutes a potential shock hazard and must be corrected immediately.

The resistance measurement should be done between accessible exposed metal parts and power cord plug prongs with the power switch "ON". The resistance should be more than 6M ohms.

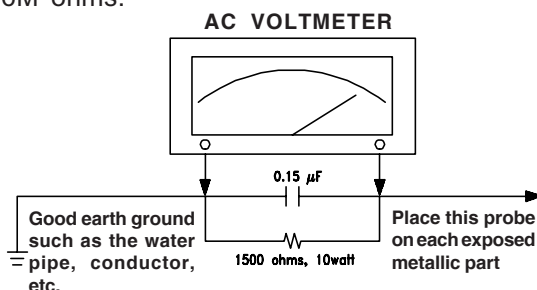

AC Leakage Current Check

PRODUCT SAFETY NOTICE

Many electrical and mechanical parts in this apparatus have special safety-related characteristics.

These characteristics are often passed unnoticed by visual inspection and the protection afforded by them cannot necessarily be obtained by using replacement components rated for a higher voltage, wattage, etc.

The replacement parts which have these special safety characteristics are identified by \triangle marks on the schematic diagram and on the parts list.

Before replacing any of these components, read the parts list in this manual carefully. The use of substitute replacement parts which do not have the same safety characteristics as specified in the parts list may create shock, fire, or other hazards.

9. Must be sure that the ground wire of the AC inlet is connected with the ground of the apparatus properly.

1. Standard Test Conditions

All tests shall be performed under the following conditions, unless otherwise specified.

- 1.1 Ambient light : 150ux (When measuring I_B , the ambient luminance $\cong 0.1\text{Cd/m}^2$)
- 1.2 Viewing distance : 50cm in front of PDP
- 1.3 Warm up time : 30 minutes
- 1.4 PDP Panel facing : no restricted
- 1.5 Measuring Equipment : Minolta CA 210 photometer
- 1.6 Magnetic field : no restricted
- 1.7 Control settings : Brightness, Contrast, Tint, Color set at Center(50)
- 1.8 Power input : 120Vac,60Hz
- 1.9 Ambient temperature : $20^{\circ}\text{C} \pm 5^{\circ}\text{C}$ ($68^{\circ}\text{F} \pm 9^{\circ}\text{F}$)
- 1.10 Display mode : 31.5KHz/60Hz (Resolution 852 x 480)
- 1.11 Other conditions :
 - 1.11.1 With image sticking protection of PDP module, the luminance will descend by time on a same still screen and rapidly go down in 5 minutes. When measuring the color tracking and luminance of a same still screen, be sure to accomplish the measurement in one minute to ensure its accuracy.
 - 1.11.2 Due to the structure of PDP, the extra-high-bright same screen should not hold over 5 minutes for fear of branding on the panel.

ELECTRICAL CHARACTERISTICS

2. Power Input

| | | | |
|-----|-------------------------------|---|---------------------------------------------------------|
| 2.1 | <u>Voltage</u> | : | 120VAC |
| 2.2 | <u>Input Current</u> | : | 3.5A |
| 2.3 | <u>Maximum Inrush Current</u> | : | <30 A (FOR AC 120V ONLY) |
| | Test condition | : | Measured when switched off for at least 20 mins |
| 2.4 | <u>Frequency</u> | : | 60Hz(±3Hz) |
| 2.5 | <u>Power Consumption</u> | : | ≤ 330W |
| | Test condition | : | full white display with maximum brightness and contrast |
| 2.6 | <u>Power Factor</u> | : | Meets IEC1000-3-2 |
| 2.7 | <u>Withstanding voltage</u> | : | 1.5kVac or 2.2kVdc for 1 sec |

3. Display

| | | | |
|-----|----------------------------|---|------------------------------------------------------|
| 3.1 | Screen Size | : | 42" Plasma display |
| 3.2 | Aspect Ratio | : | 16:9 |
| 3.3 | Pixel Resolution | : | 852x480 |
| 3.4 | Peak Brightness | : | 1500 cd/m ² (Panel module without filter) |
| 3.5 | Contrast Ratio (Dark room) | : | 10000:1 (Panel module without filter) |
| 3.6 | Viewing Angle | : | Over 160° |
| 3.7 | OSD language | : | English, Spaish, French |

4. Signal

4.1 AV & Graphic input

| | | | |
|--------|-------------------|---|------------------------------------------------------------------------------------------|
| 4.1.1 | TV standard | : | NTSC/ATSC |
| 4.1.2 | TV Tuning system | : | 181CH (for NTSC), 2~69CH (for ATSC) |
| 4.1.3 | CATV | : | 125CH (for NTSC) |
| 4.1.4 | Composite signal | : | AV |
| 4.1.5 | Y,C Signal | : | S-Video |
| 4.1.6 | omponent signal | : | YPbPr HDTV compatible |
| 4.1.7 | Graphic I/P | : | D-Sub 15 pin detachable cable |
| 4.1.8 | HDMI | : | HDMI |
| 4.1.9 | PnP compatibility | : | DDC 1.0 |
| 4.1.10 | I/P frequency | : | f _H : 31.5kHz to 60kHz/f _V : 56.25Hz to 75Hz (640x480 recommended) |

4.2 Audio input

Audio I/P(L/Rx5) : 1 for DVI / D-Sub
2 for YPbPr
1 for S-Video
1 for AV

4.3 Audio output

Audio O/P(L/Rx1) : Monitor out(L/R)

SPDIF : Optical x 1 (only for ATSC)

5. Environment

5.1 Operating environment

5.1.1 Temperature : 5° to 33°C
5.1.2 Relative humidity: 20% to 85%(non-condensing)

5.2 Storage and Transport

5.2.1 Temperature : -20°C to 60°C(-4° to 140°F)
5.2.2 Relative humidity: 5% to 95%

6. Panel Characteristics

6.1 Type : LG V7
6.2 Size : 42", 1005mm(width)x597mm(height)x61mm(depth)±1 mm)
6.3 Aspect ratio : 16:9
6.4 Viewing angle : Over 160°
6.5 Resolution : 852x480
6.6 Weight : 14.7kg ±0.5 kg (Net 1EA)
6.7 Color : 1073.7 million colors by combination of 10 bits R,G,B digital
6.8 Contrast : Average 100:1 (In a bright room with 100Lux at center)
Typical 10000:1 (In a dark room 1/100 White Window pattern at center).
6.9 Peak brightness : Typical 1500cd/m² (1/100 White Window)
6.10 Color Coordinate Uniformity : Contrast; Brightness and Color control at normal setting
Test Pattern : Full white pattern

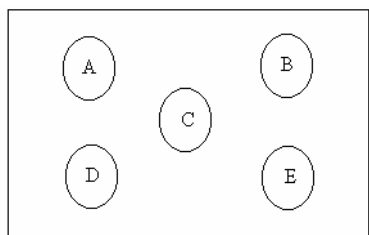

Average of point A,B,C,D and E +/- 0.01

6.11 Color temperature : Contrast at center (50); Brightness center (50);
 Colortemperature set at Middle
 $x=0.285\pm0.02$
 $y=0.293\pm0.02$

6.12 Cell Defect Specifications
 Subject to Panel supplier specification as appends.

7. Front Panel Control Button

- 7.1 CH Up / Down Button : Press the key to changing the channel up or down.
When selecting the item on OSD menu.
- Volume Up/ Down Button : Press the key to increase the volume up or down.
When selecting the adjusting item on OSD menu
increase or decrease the data-bar.
- Menu Button : Press the key to display or exit the menu.
It has the function of Enter in the Menu.
- Input Button : Press the key to select the input signals source.
- 7.2 Stand by Button : Switch on main power, or switch off to enter power
Saving modes.
- 7.3 Main Power Switch : Turn on or off the unit.

8. OSD Function

Full on screen display

9. Agency Approvals

| | |
|-----------|-------------|
| Safety | UL60950 |
| Emissions | FCC class B |

10. Reliability

10.1 MTBF: 20,000 hours (Use moving picture signal at 25°C ambient)

11. Accessories: User Manual x 1, Remote Control x 1, Stand x 1, Power Cord x 1, Battery x2.

12. Remote Control

- 1 **Standby** (⏻): Press to turn on and off.
- 2 **Mute** (🔇): Press to mute the sound. Press again to restore the sound.
- 3 **0~9 Number Buttons**: Press 0~9 to select a channel, and used to input the password; the channel changes after 2 seconds.
- 4 **EPG (Electronic Program Guide)**: Press to display EPG mode. Press again to exit EPG mode.
- 5 **Input**: Press to select the signal source, such as DTV, TV, AV, S-Video, YPbPr 1, YPbPr 2, VGA, or HDMI.
- 6 **DTV**: Press to choose DTV directly.
- 7 **Dot**: Press number buttons with it to select the channels directly in DTV.
- 8 **VOL +/-**: Press to adjust the volume.
- 9 **CH +/-**: Press to select the channel forward or backward.
- 10 **MTS**: Press repeatedly to cycle through the Multi-channel TV sound (MTS) options: Mono, Stereo and SAP (Second Audio Program).
- 11 **◀, ▶, ▲, ▼, Enter**: Press **◀, ▶, ▲, ▼** to move the on-screen cursor. To select an item, press **Enter** to confirm.
- 12 **Exit**: Press this button to exit.
- 13 **Menu**: Press to enter into the on-screen setup menu, press again to exit.
- 14 **V-Chip**: Press to select the child protect mode.
- 15 **CCD**: Press to select the Closed Caption mode.
- 16 **Freeze**: Press to freeze the picture, press again to restore the picture.
- 17 **Display**: Press to display the channel information and it disappear after 3 seconds.
- 18 **Favorite**: Press repeatedly to cycle through the favorite channel list.
- 19 **Add/Erase**: Press to add or delete favorite or dislike channels.
- 20 **S. Mode**: Press repeatedly to select the sound mode: Normal, News, Cinema, Concert and User.
- 21 **PIC Size**: Press repeatedly to cycle through the picture size that best corresponds your viewing requirements: Full, 4:3 and Panoramic.

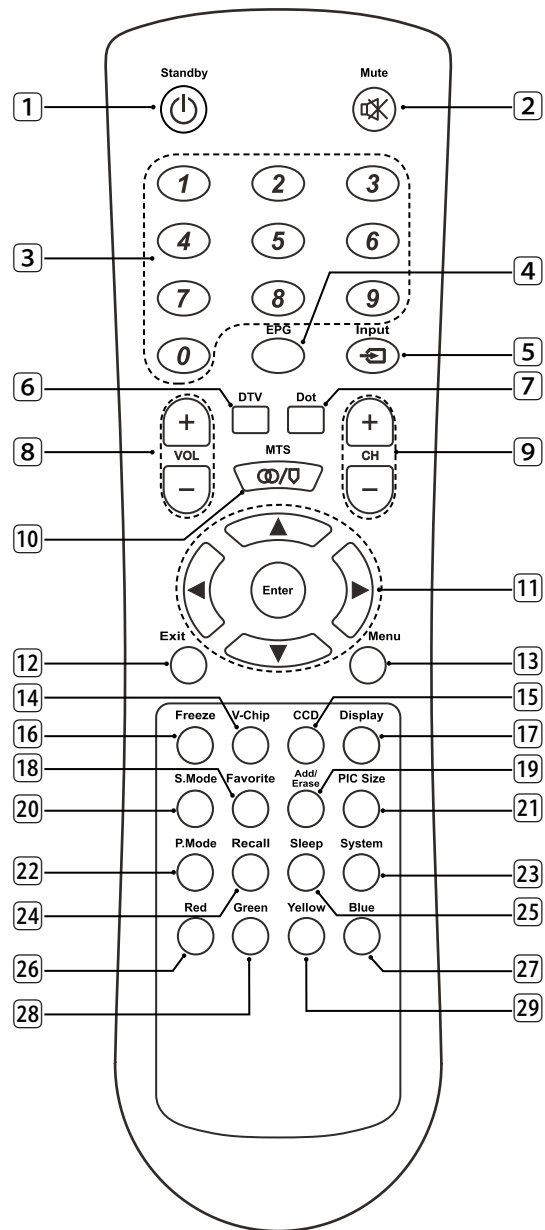

(Continued on next page)

- 22 **P. Mode:** Press repeatedly to cycle through the picture mode: Cinema, Normal, Vivid, Hi-Bright and User.
- 23 **System:** Press repeatedly to cycle through the system options: AUTO, NTSC 3.58 and PAL. (Only for AV or S-Video)
- 24 **Recall:** Press to return to previous channel.
- 25 **Sleep:** Press repeatedly until it displays the time in minutes (15 Min, 30 Min, 60 Min, 90 Min, 120 Min and, Off) that you want the TV to remain on before shutting off. To cancel sleep time, press **Sleep** button repeatedly until sleep Off appears.
- 26 **Red:** Press this button to access the red item or page.
- 27 **Blue:** Press this button to access the blue item or page.
- 28 **Green:** Press this button to access the green item or page.
- 29 **Yellow:** Press this button to access the yellow item or page.

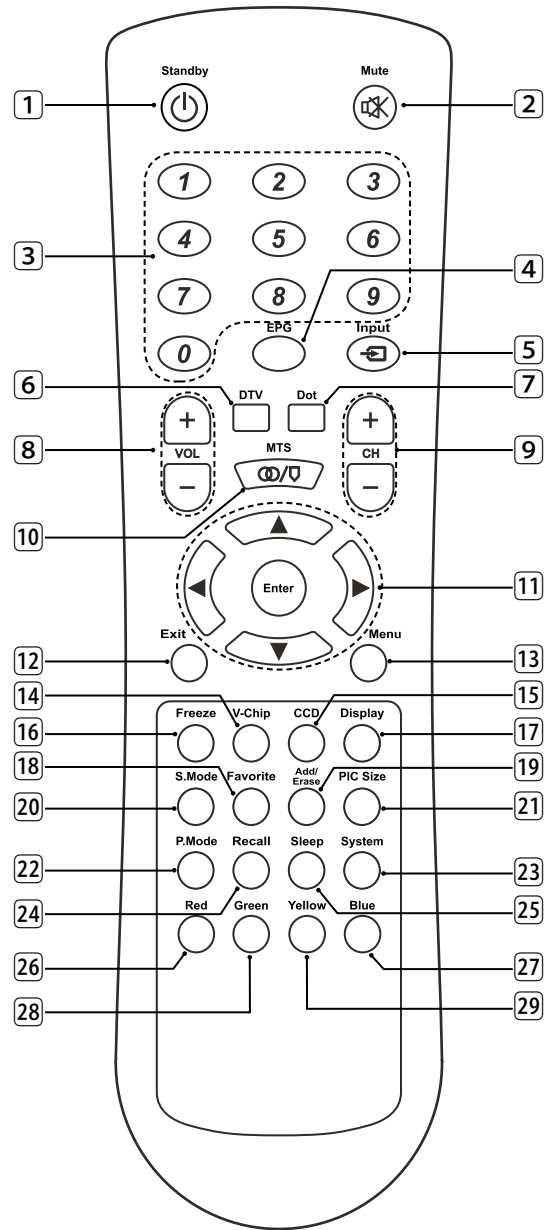

Note: 1 Press **CH +/-** button on the remote control can turn on TV set from standby mode.
 2 If the volume is too loud from the other external devices (such as, DVD, VCR, etc.), we suggest that you press **VOL +/-** button to adjust the volume of PDP into appropriate. If the volume of the other external devices (such as, DVD, VCR, etc.) and PDP are too loud, the audio quality will be influenced.

Insertion of Batteries:

- Turn the remote control upside down, press and slide off the battery cover.
- Insert two 1.5V (AAA) batteries into the compartment, take care to observe the ⊕ and ⊖ markings indicated inside.
- Replace the cover and slide in reverse until the lock snaps.

13. Support the Signal Mode

A. VGA Mode

| Resolution | Horizontal Frequency (KHz) | Vertical Frequency (Hz) |
|------------|----------------------------|-------------------------|
| 640 x 480 | 31.50 | 60.00 |
| | 37.86 | 72.81 |
| 800 x 600 | 35.16 | 56.25 |
| | 37.90 | 60.32 |
| | 46.90 | 75.00 |
| | 48.08 | 72.19 |
| 1024 x 768 | 48.40 | 60.00 |

B.YPbPr Mode

| Resolution | Horizontal Frequency (KHz) | Vertical Frequency (Hz) |
|------------------|----------------------------|-------------------------|
| 480i | 15.734 | 59.94 |
| 480p(720x480) | 31.468 | 59.94 |
| 720p(1280x720) | 45.00 | 60.00 |
| 1080i(1920x1080) | 33.75 | 60.00 |

C.HDMI Mode

| Resolution | Horizontal Frequency (KHz) | Vertical Frequency (Hz) |
|------------|----------------------------|-------------------------|
| 480p | 31.468 | 59.94 |
| 720p | 45.00 | 60.00 |
| 1080i | 33.75 | 60.00 |

- When the signal received by the Display exceeds the allowed range, a warning message shall appear on the screen.
- You can confirm the input signal format from the on-screen.

PHYSICAL CHARACTERISTICS

14. Power Cord

Length : 1.8m nominal
 Type : optional

15. Cabinet

15.1 Color : "Black" colour as defined by colour plaque reference number

15.2 Weight

Net weight : 33.6 kg(with stand) /31.4kg(without stand)
 Gross weight : 41.0 kg

15.3 Dimensions(w/o stand)

Width : 1050 mm
 Height : 657 mm
 Depth : 99.5 mm

□ BLOCK DIAGRAM

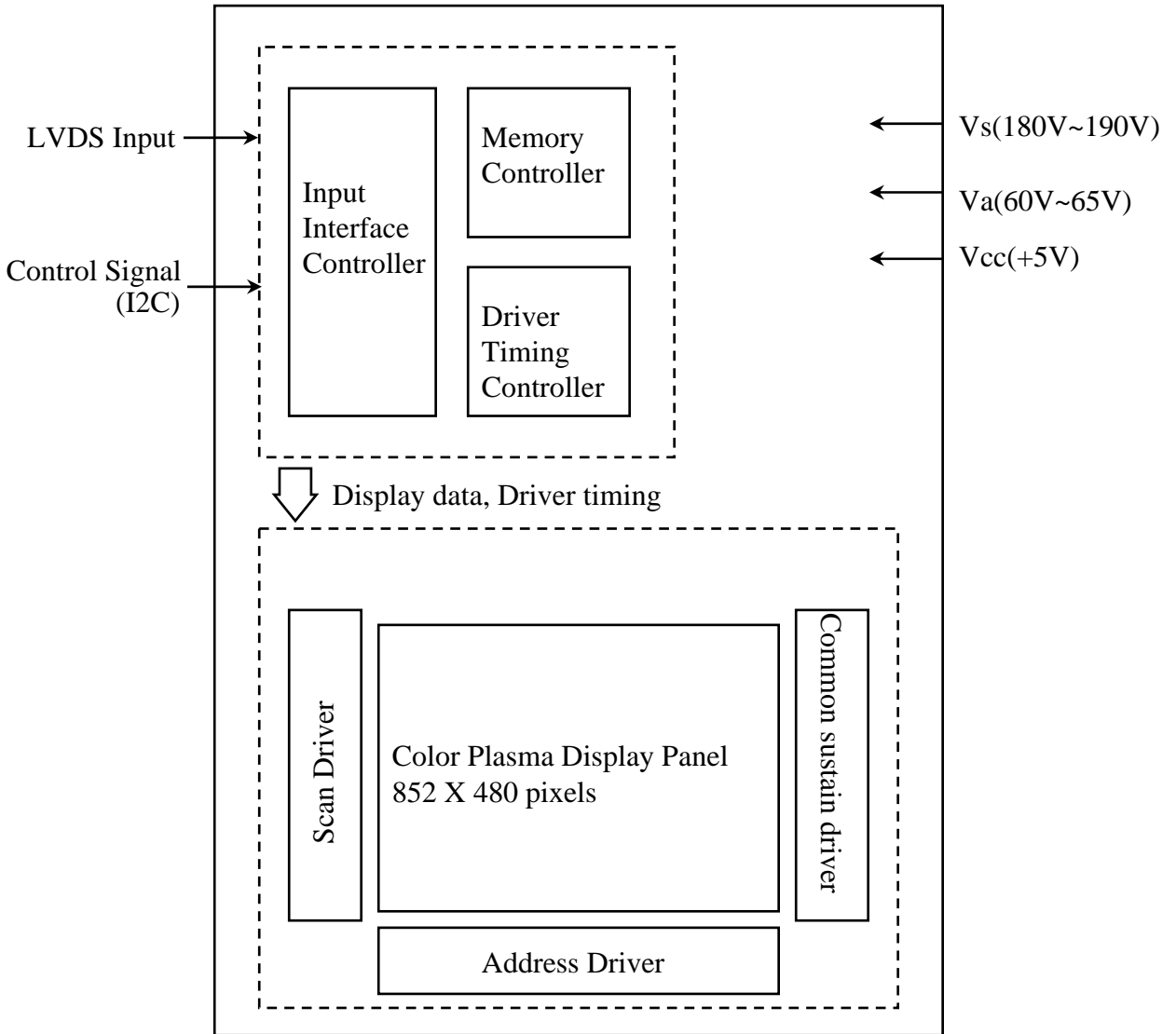

Applied Voltage level is specified at the time when Full-White pattern is displayed on the panel.

ATSC SYSTEM

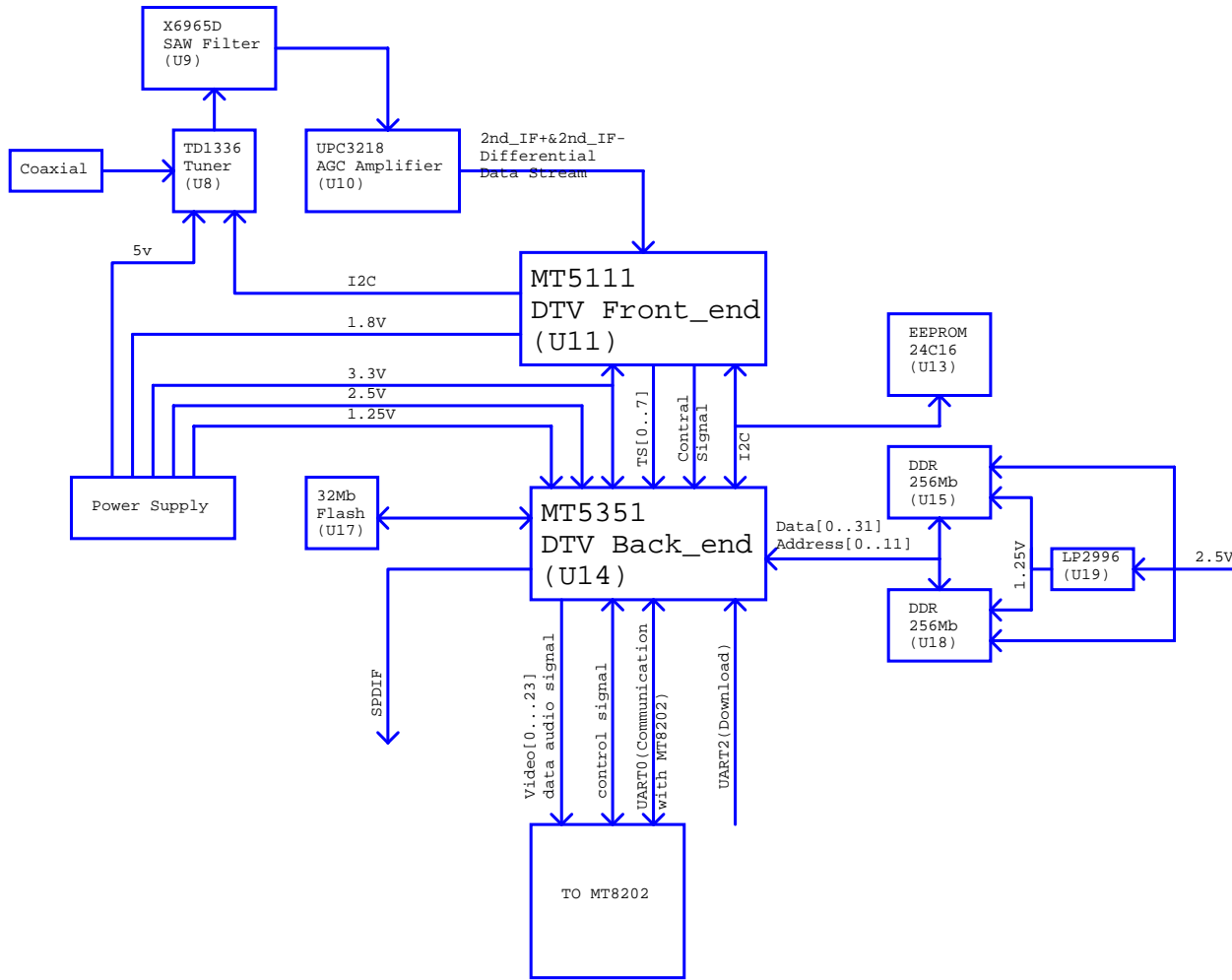

KAWA Confidential

ZhongShan KAWA Electronic Inc.

| | | | |
|---------------------|-------------------------|--------------------|--------|
| MT5351 Block | | | |
| File | | | |
| Size | Document Number | Drawn: <Designer> | Rev |
| c | AKAI_MT8202_MT5351_V1.0 | Checked: <Checker> | 1 |
| Date: | Friday, March 17, 2006 | Sheet | 1 of 2 |

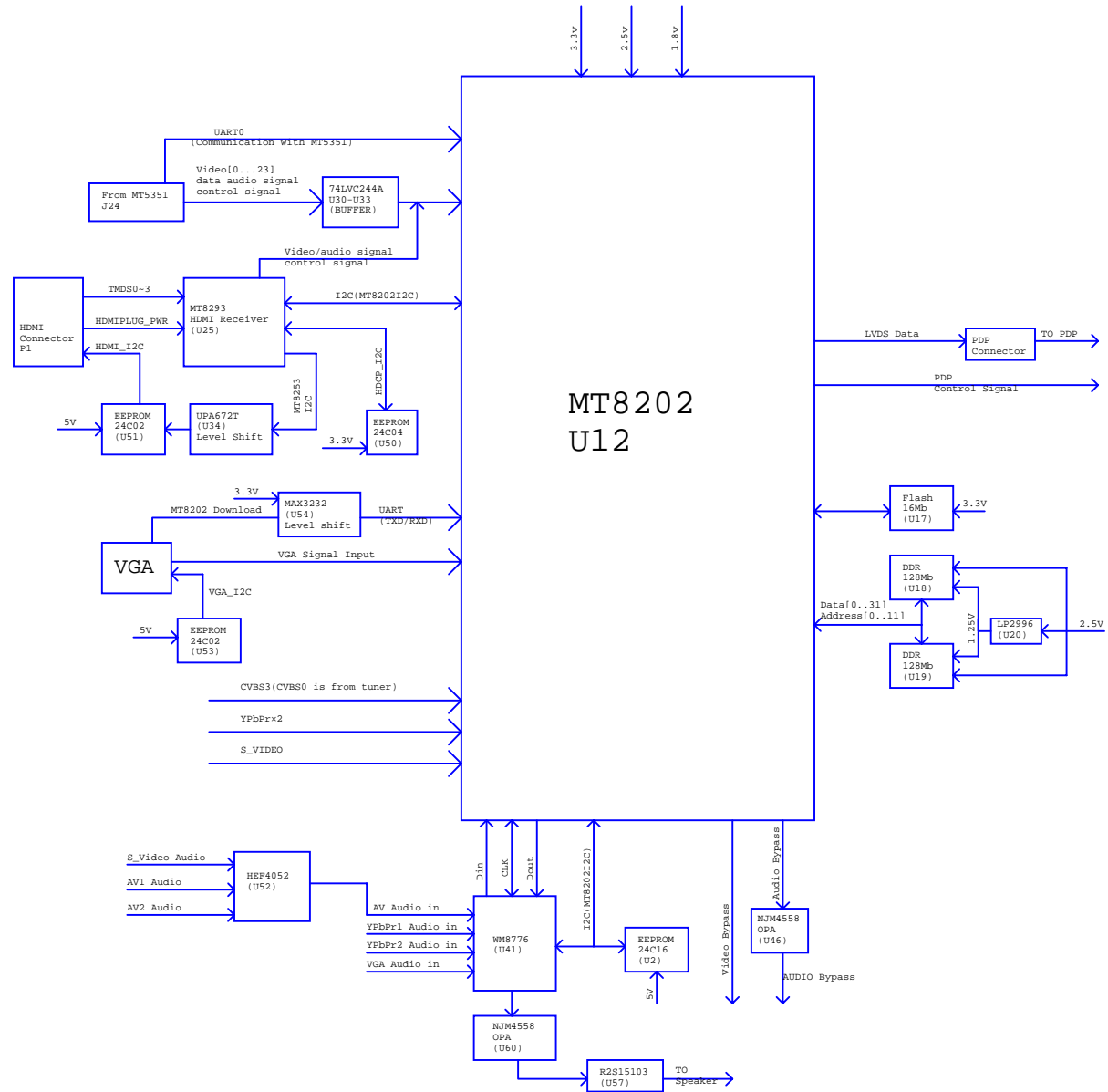

Circuit Diagram

- **Power supply board of PDP Module, 1H273W**
- **Main (Video) board**
- **Audio/Tuner board**
- **ATSC board**
- **Keypad board**
- **Remote control receiver board**
- **External L/R Speakers board**
- **Remote control board**

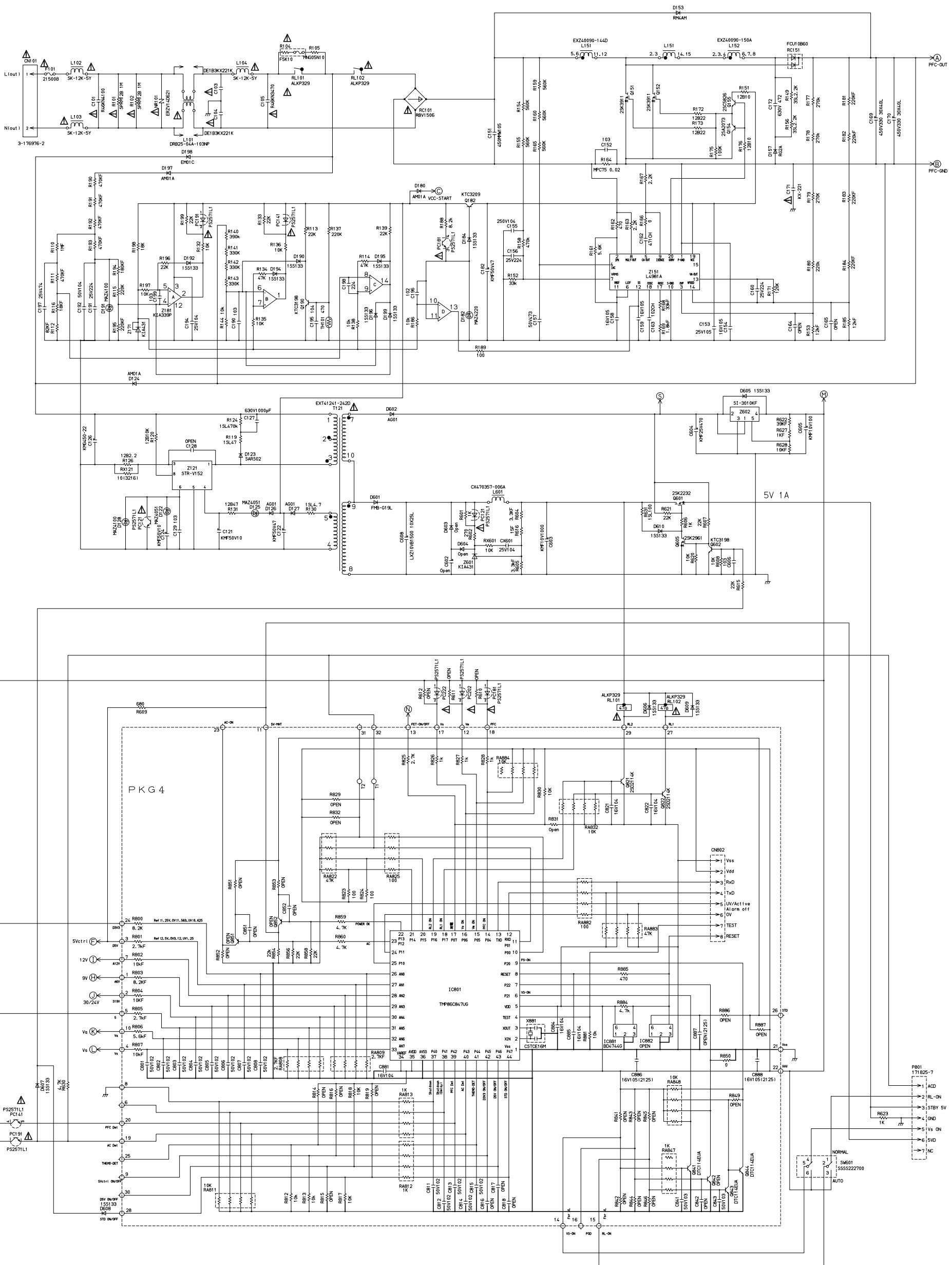

1H273W-3
 CIRCUIT DIAGRAM
 DWG. NO. 図番
 CPF33000-524
 設計者 M. Hashimoto
 検査者
 承認者
 発行日 2023.05.08-23
 第3角法
 SANKEN ELECTRIC CO., LTD.
 サンケン電気株式会社

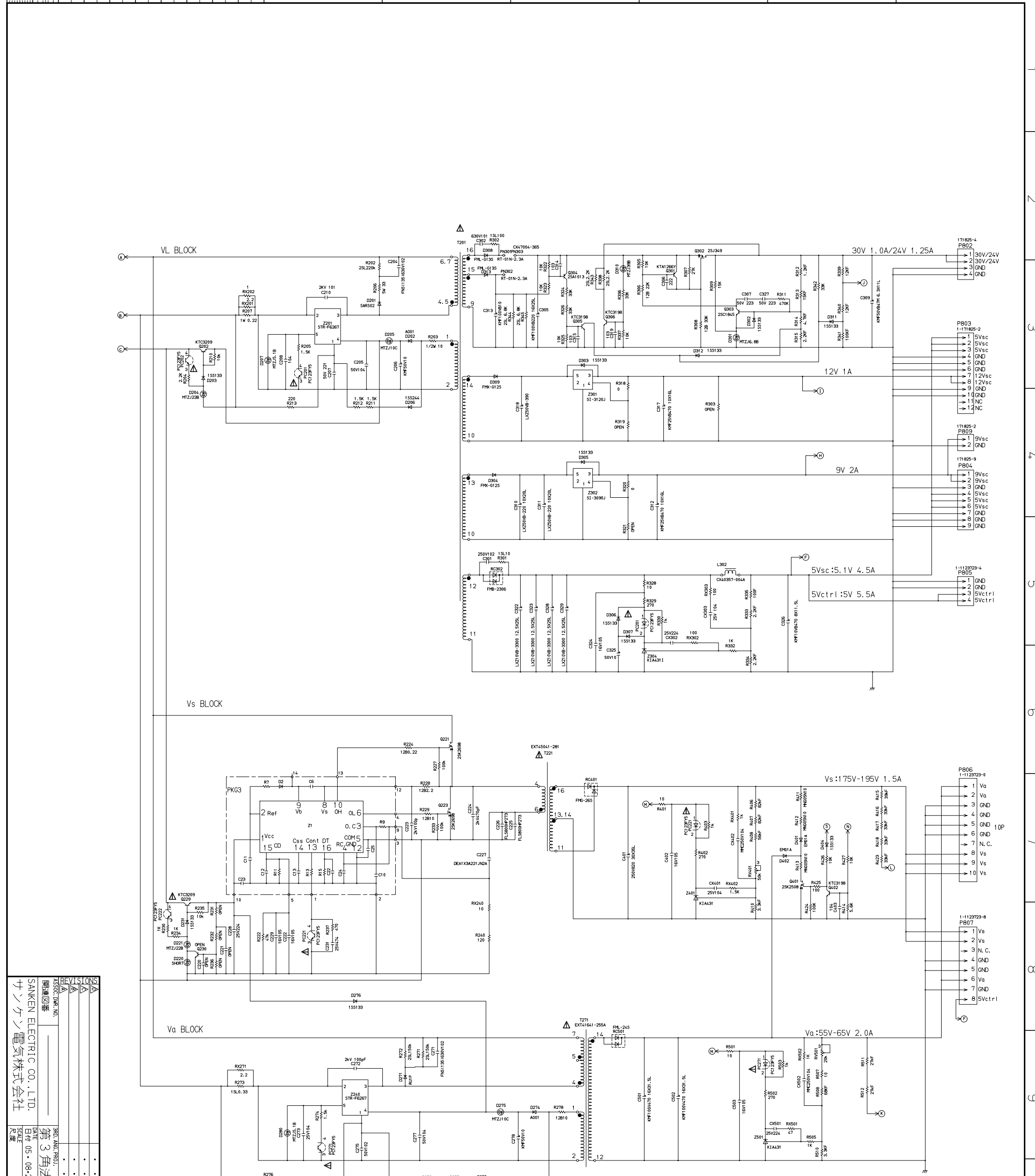

| | |
|--------------------------|-------------|
| REV. NO. | 3 |
| DATE | 05-08-23 |
| BY | M.Hashimoto |
| CHECKED BY | |
| DESIGNED BY | |
| SAKEN ELECTRIC CO., LTD. | |
| サケン電気株式会社 | |
| 図番 | 第3角法 |
| 製作 | |
| 承認 | |
| 印刷 | |
| 確認 | |
| 検査 | |
| 承認 | |
| 印刷 | |
| 確認 | |
| 検査 | |
| 承認 | |
| 印刷 | |
| 確認 | |
| 検査 | |

TITLE: 名称
 1H273W-3
 CIRCUIT DIAGRAM
 DWG. NO.: 図番
 CPF33000-525

MT8202E (PBGA388) LCDTV BOARD 4 LAYERS FOR AKAI

1. INDEX / POWER / RESET / EEPROM
2. LDO
3. MT8202E PBGA388
4. MT8202 DECOUPLING
5. DDR MEMORY & FLASH
6. MT5351 INTERFACE
7. HDMI MT8293
8. DAUGHTER BOARD IN
9. WM8776 & VIDEO BYPASS
10. AUDIO / VIDEO IN CIRCUIT
11. VGA & PC AUDIO IN
12. LVDS OUT
13. BACK LIGHT / KEYPAD
14. TUNER IN
15. AV IN
16. AUDIO IN
17. AUDIO Amplifier

| | | |
|-----------|-------------|--------|
| LVDSVDD | >>LVDSGND | 2,3,4 |
| SCL | >>SCL | 9,14 |
| SDA | >>SDA | 9,14 |
| URST# | >>URST# | 3 |
| 8202UP3_1 | >>8202UP3_1 | 3 |
| GPIO2 | >>GPIO2 | 3,12 |
| GPIO4 | >>GPIO4 | 3 |
| GPIO14 | >>GPIO14 | 3,13 |
| GPIO19 | >>GPIO19 | 3,13 |
| 9V | >>9V | 7,9,14 |
| 12V | >>12V | 12,13 |
| RELAY_ON | >>RELAY_ON | 12 |
| VS_ON | >>VS_ON | 12 |

| Rev | History | P# | Date |
|---------------------------------------------------------------|----------------------------------------------------|----|------------|
| AKAI_MT8202_27US_LVDS_V0.0 AKAI_MT8202_27US_HDMI_LVDS_V0.0 | New ADD HDMI / VIDEO / AUDIO CONNECTOR INPUT IN | | 2005/11/22 |

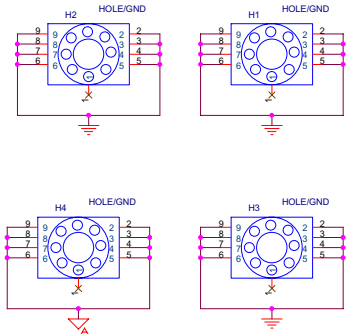
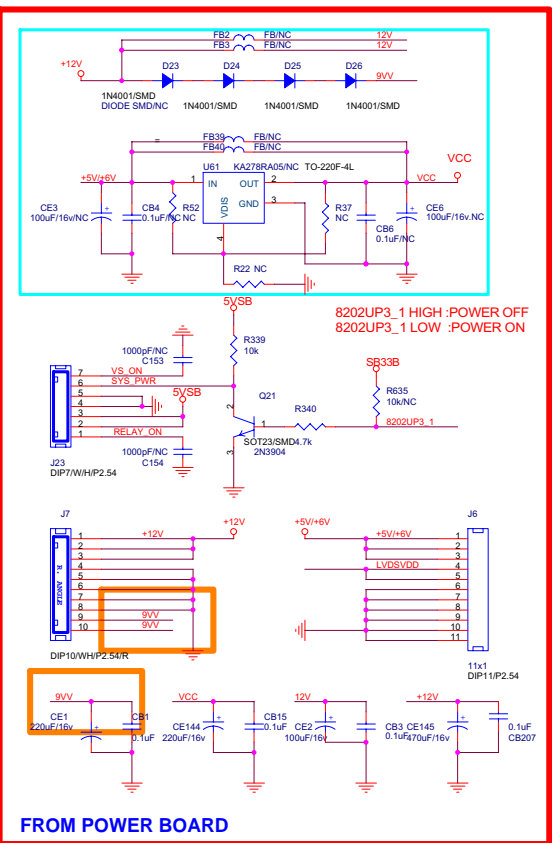
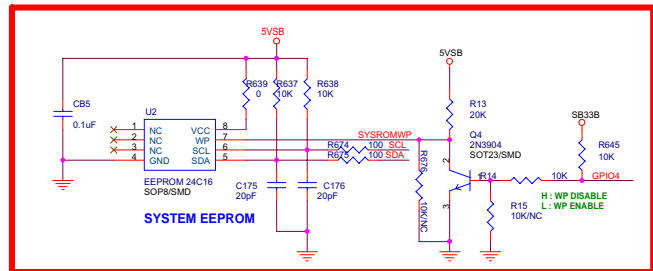
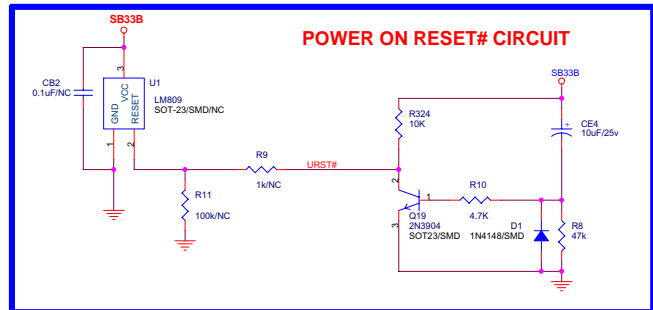
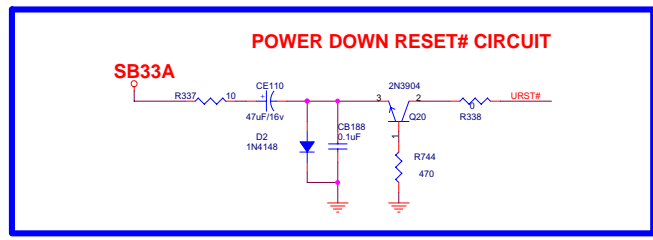
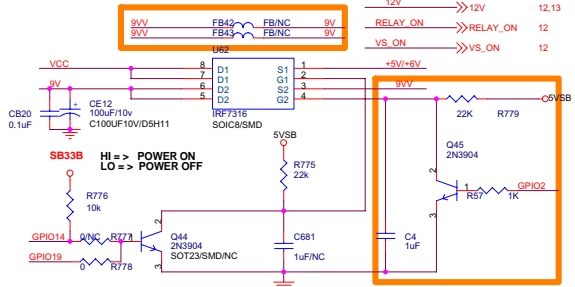

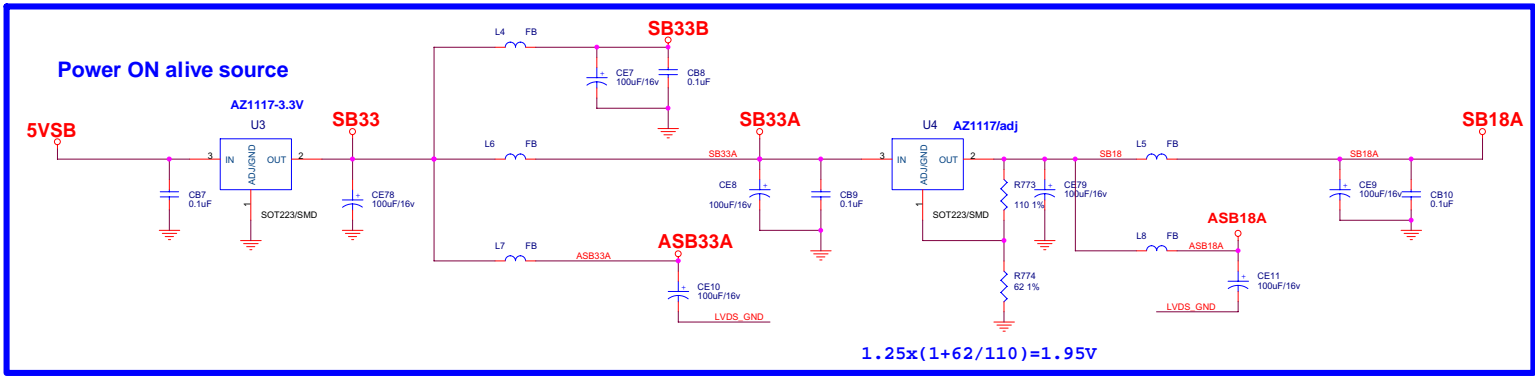

LVDS_GND >> LVDS_GND 3.4.12
 VFE_GND >> VFE_GND 3.4.8.11
 VFE_GND1 >> VFE_GND1 3.4.8.11

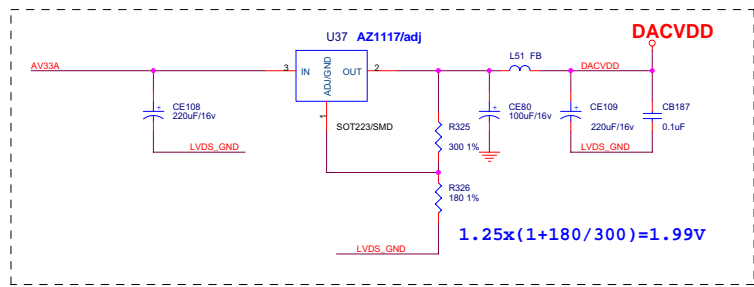
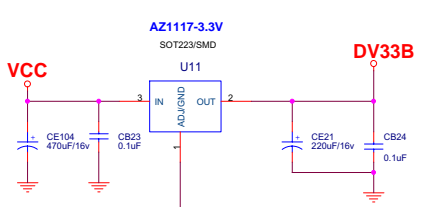
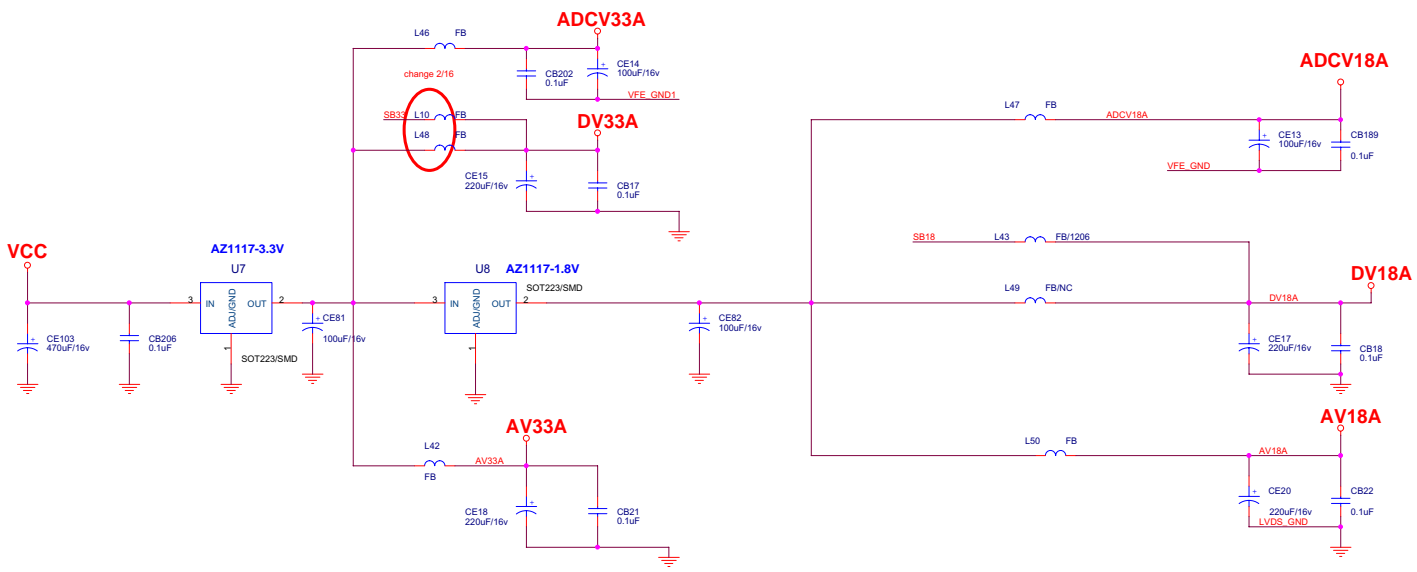

KAWA Confidential

ZhongShan KAWA Electronic Inc.

| | | | |
|-------|----------------------------|--------------------|---------|
| File | LDO | | |
| Size | Document Number | Drawn: <Designer> | Rev |
| C | AKAI_MT8202_27US_LVDS_V0.0 | Checked: <Checker> | 1 |
| Date: | Monday, February 27, 2006 | Sheet | 2 of 17 |

STANDBY ANALOG POWER

ASB18A

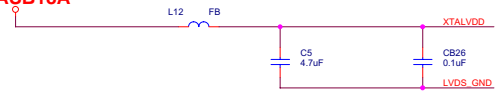

ASB33A

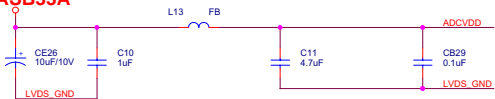

NORMAL VIDEO DAC POWER

DACVDD

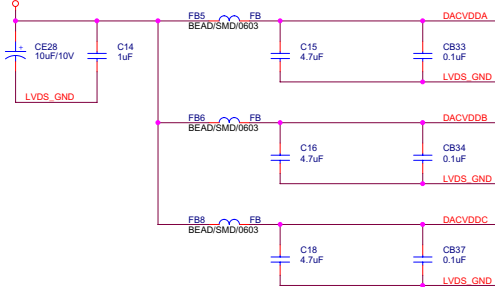

NORMAL VIDEO DAC POWER

AV33A

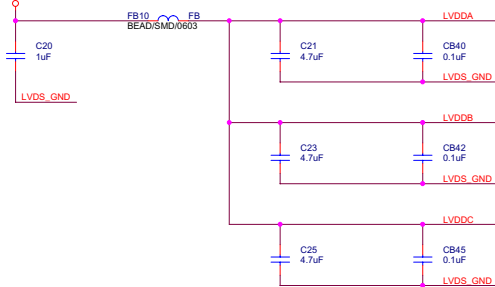

NORMAL AUDIO ADC / DAC POWER

ADC33A

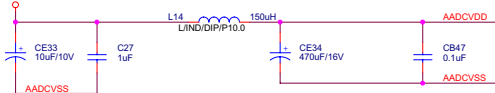

ADC33A

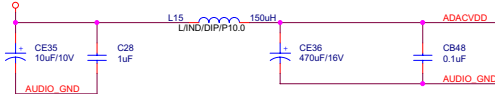

NORMAL ANALOG POWER

ASB18A

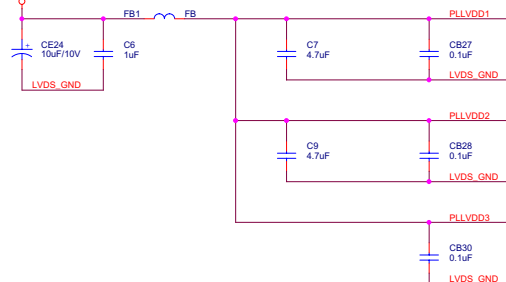

AV18A

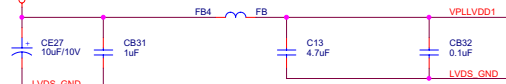

AV33A

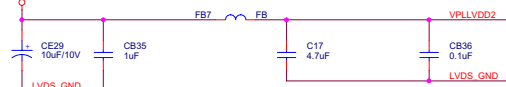

NORMAL VIDEO ADC POWER

ADC33A

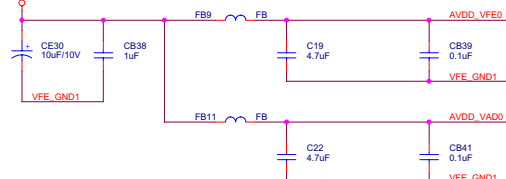

ADC18A

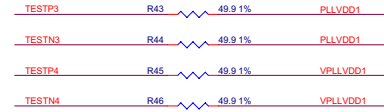
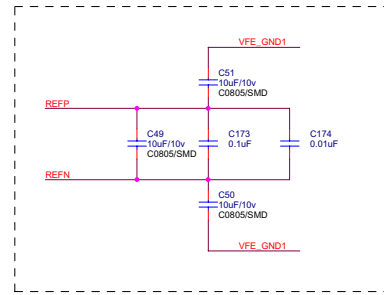
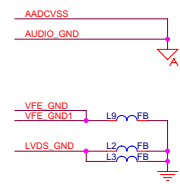
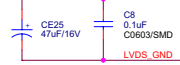
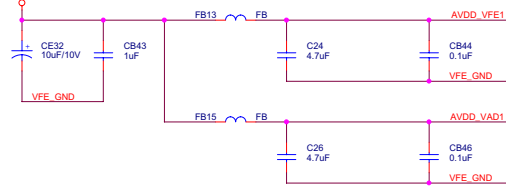

MT8202 DIGITAL POWER & DECOUPLING

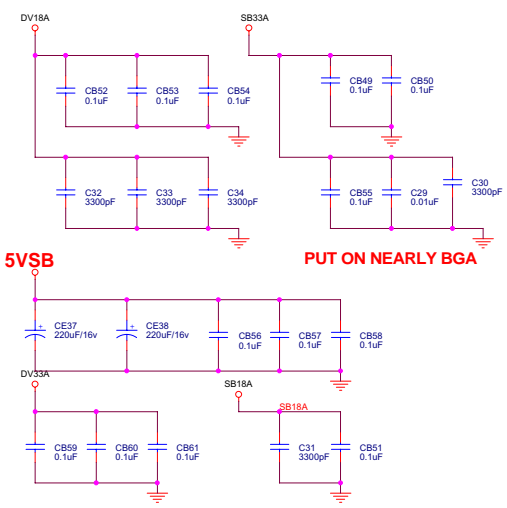

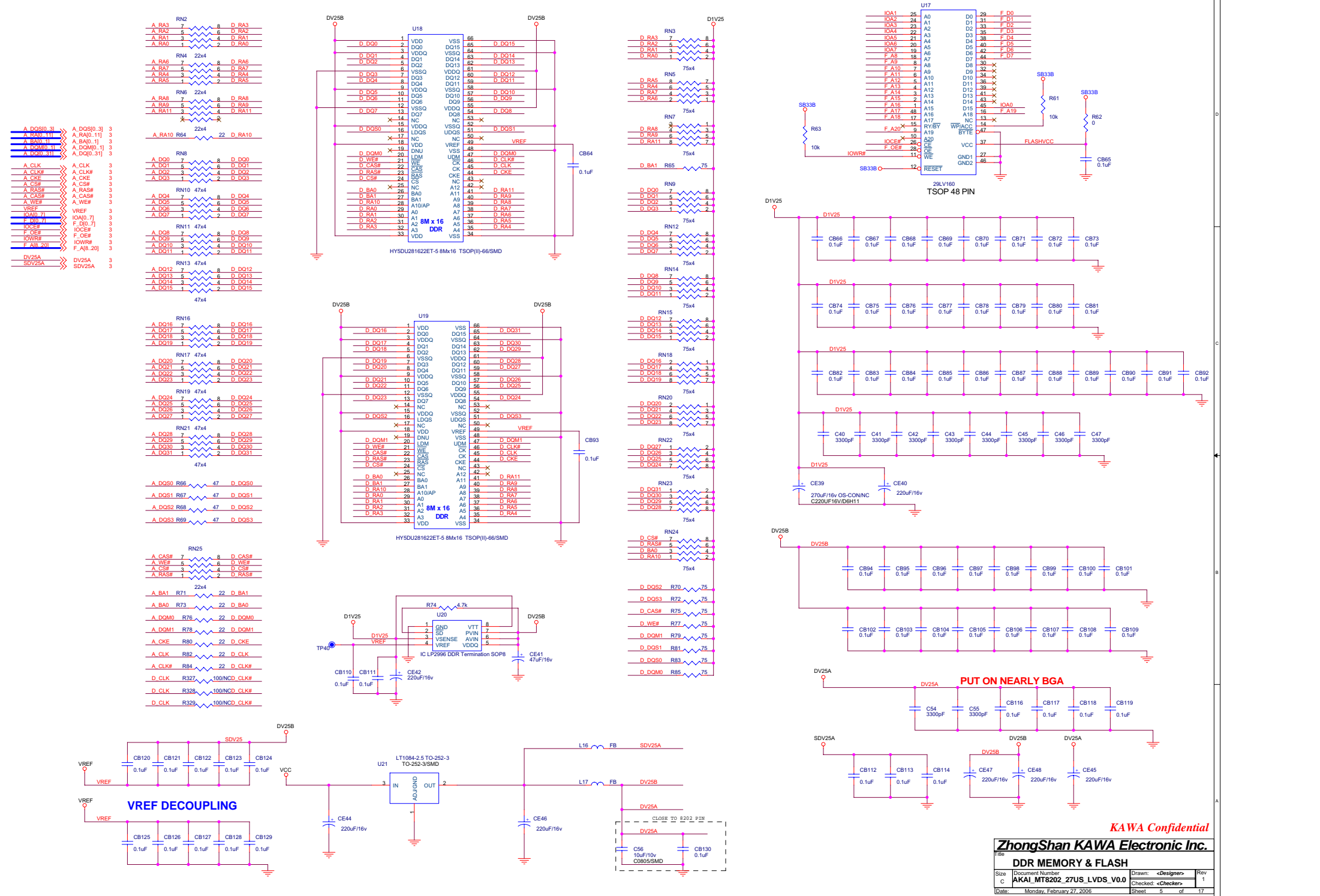

- A.DQS0_0 >> A.DQS0_0 3
- A.DQM0[1:1] >> A.RA0[0:1] 3
- A.BA0_0 >> A.BA0_0 3
- A.DQM0_1 >> A.DQM0_1 3
- A.DQS0_1 >> A.DQS0_1 3
- A.CLK >> A.CLK 3
- A.CLKE >> A.CLKE 3
- A.CKE >> A.CKE 3
- A.CSF >> A.CSF 3
- A.RAS# >> A.RAS# 3
- A.CAS# >> A.CAS# 3
- A.WE# >> A.WE# 3
- VREF >> VREF 3
- IOA0_7 >> IOA0_7 3
- F.D[0:7] >> F.D[0:7] 3
- IOCE# >> IOCE# 3
- F.OE# >> F.OE# 3
- IOWR# >> IOWR# 3
- F.A[8:20] >> F.A[8:20] 3
- DV25A >> DV25A 3
- SDV25A >> SDV25A 3

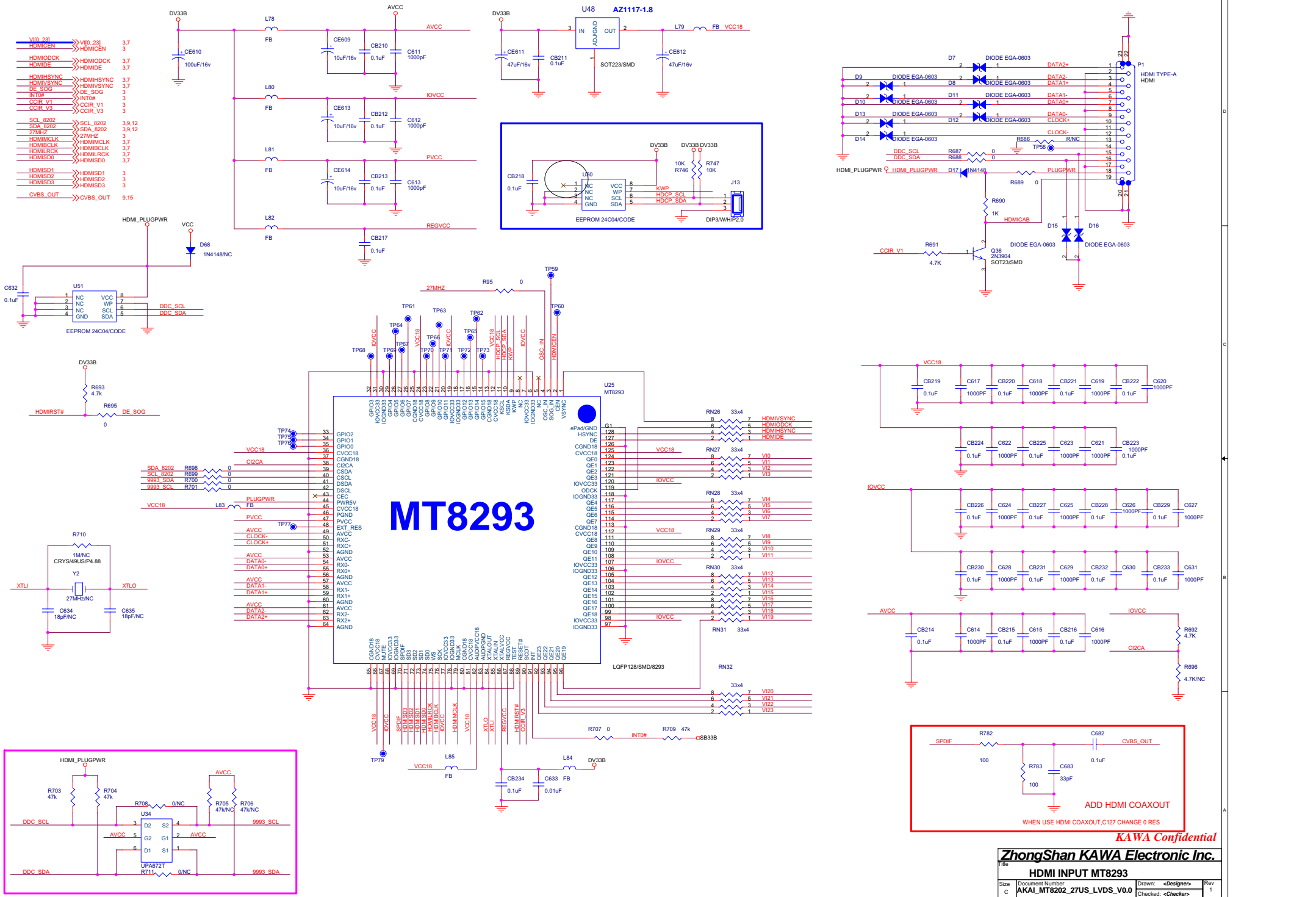

KAWA Confidential

ZhongShan KAWA Electronic Inc.

| | | | |
|-------|----------------------------|--------------------|---------|
| File | | HDMI INPUT MT8293 | |
| Size | Document Number | Drawn: <Designer> | Rev |
| C | AKAI_MT8202_27US_LVDS_V0.0 | Checked: <Checker> | 1 |
| Date: | Monday, February 27, 2006 | Sheet | 6 of 17 |

| | | | |
|-----------|----|-----------|--------|
| HDMIMCLK | >> | HDMIMCLK | 3,6 |
| HDMIBCLK | >> | HDMIBCLK | 3,6 |
| HDMILRCK | >> | HDMILRCK | 3,6 |
| HDMISD0 | >> | HDMISD0 | 3,6 |
| HDMIDE | >> | HDMIDE | 3,6 |
| HDMIODCK | >> | HDMIODCK | 3,6 |
| HDMIHSYNC | >> | HMIHSYNC | 3,6 |
| HDMIVSYNC | >> | HDMIVSYNC | 3,6 |
| VII0..231 | >> | VI[0..23] | 3,6 |
| TXD | >> | TXD | 3,11 |
| RXD | >> | RXD | 3,11 |
| TXD1 | >> | TXD1 | 3 |
| RXD1 | >> | RXD1 | 3 |
| SCL1 | >> | SCL1 | 3 |
| SDA1 | >> | SDA1 | 3 |
| GPIO3 | >> | GPIO3 | 3 |
| CCIR_V6 | >> | CCIR_V6 | 3 |
| SCL0 | >> | SCL0 | 3 |
| SDA0 | >> | SDA0 | 3 |
| 9V | >> | 9V | 1,9,14 |

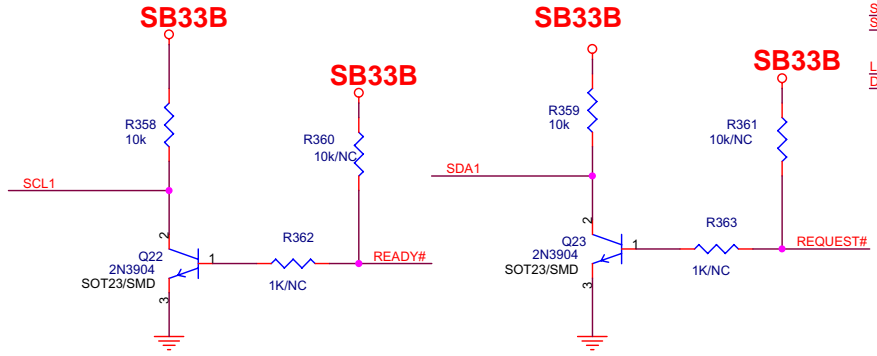

DTV POWER CONTROL

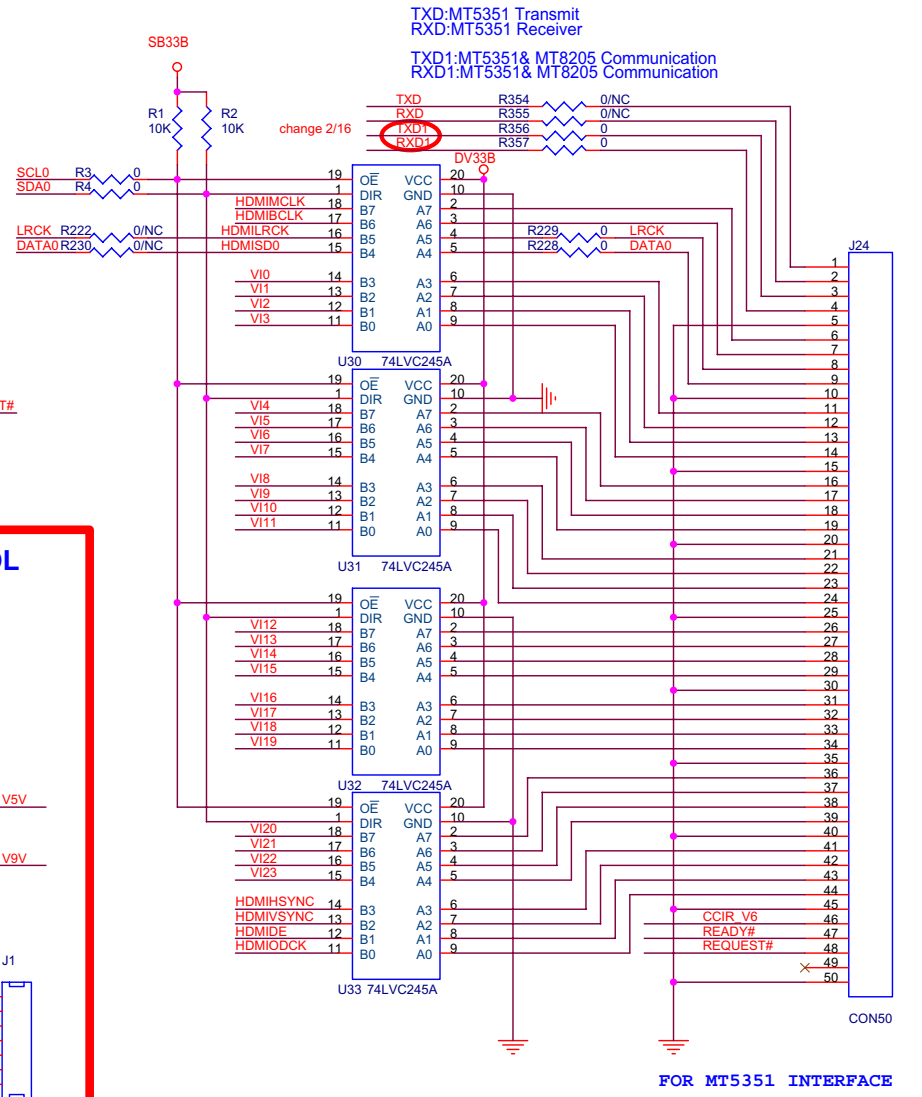
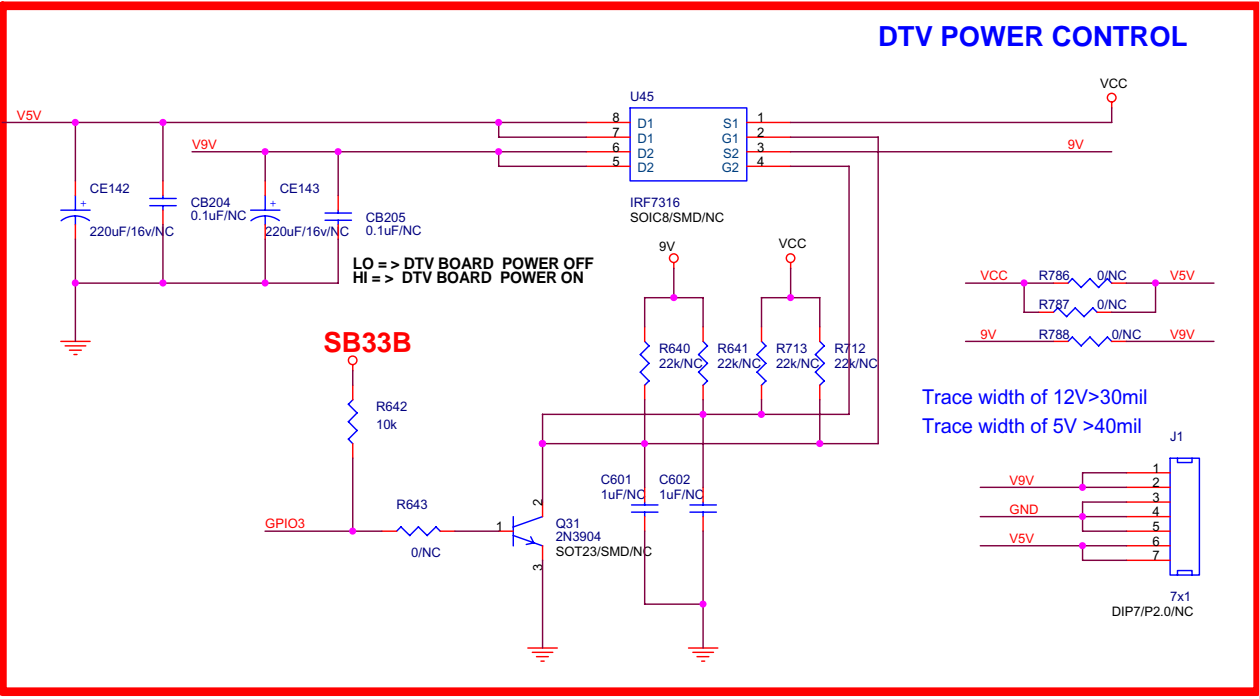

KAWA Confidential

| | | | |
|---------------------------------------|----------------------------------------------------|--------------------|--------|
| ZhongShan KAWA Electronic Inc. | | | |
| Title: MT5351 INTERFACE | | | |
| Size: B | Document Number: AKAL MT8202_27US_LVDS_V0.0 | Drawn: <Designer> | Rev: 1 |
| Date: Monday, February 27, 2006 | | Checked: <Checker> | |
| | | Sheet: 7 | of 17 |

INPUT

| | | |
|----------|----------|----------|
| ADC_IN0 | ADC_IN0 | 3 |
| CCIR_V0 | CCIR_V0 | 3 |
| CCIR_V5 | CCIR_V5 | 3 |
| CCIR_V7 | CCIR_V7 | 3 |
| GPI011 | GPI011 | 3 |
| GPI015 | GPI015 | 3 |
| GPI016 | GPI016 | 3 |
| GPI017 | GPI017 | 3 |
| GPI018 | GPI018 | 3 |
| VFE_GND | VFE_GND | 2,3,4,11 |
| AADDRESS | AADDRESS | 3,4,10 |
| AV1_R | AV1_R | 15 |
| AV1_L | AV1_L | 15 |
| AV2_R | AV2_R | 15 |
| AV2_L | AV2_L | 15 |
| SY_R | SY_R | 15 |
| SY_L | SY_L | 15 |
| Y2_INB | Y2_INB | 15 |
| Y2_GNDB | Y2_GNDB | 10,15 |
| CB2_INB | CB2_INB | 15 |
| CB2_GNDB | CB2_GNDB | 10,15 |
| CR2_INB | CR2_INB | 15 |
| CR2_GNDB | CR2_GNDB | 10,15 |
| Y3_INB | Y3_INB | 15 |
| Y3_GNDB | Y3_GNDB | 15 |
| CB3_INB | CB3_INB | 15 |
| CB3_GNDB | CB3_GNDB | 15 |
| CR3_INB | CR3_INB | 15 |
| CR3_GNDB | CR3_GNDB | 15 |
| 9V | 9V_GNDB | 17,9,14 |

OUTPUT

| | | |
|---------|---------|----|
| AV_R | AV_R | 9 |
| AV_L | AV_L | 9 |
| Y0 | Y0 | 10 |
| CB0 | CB0 | 10 |
| CR0 | CR0 | 10 |
| Y0_GND | Y0_GND | 10 |
| CB0_GND | CB0_GND | 10 |
| CR0_GND | CR0_GND | 10 |

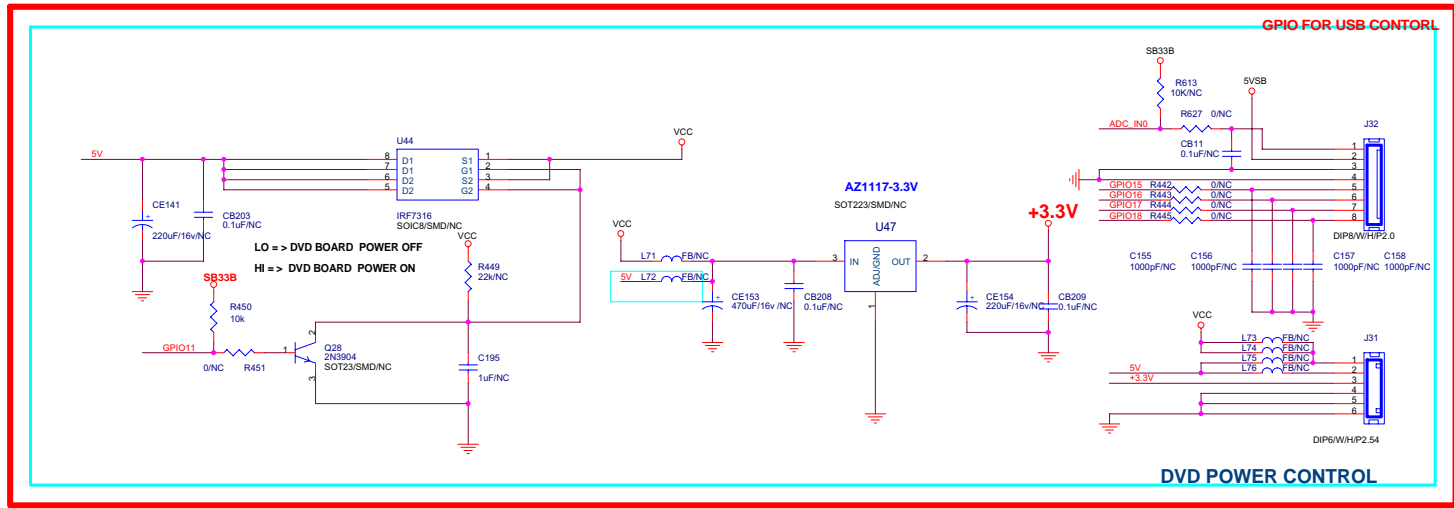
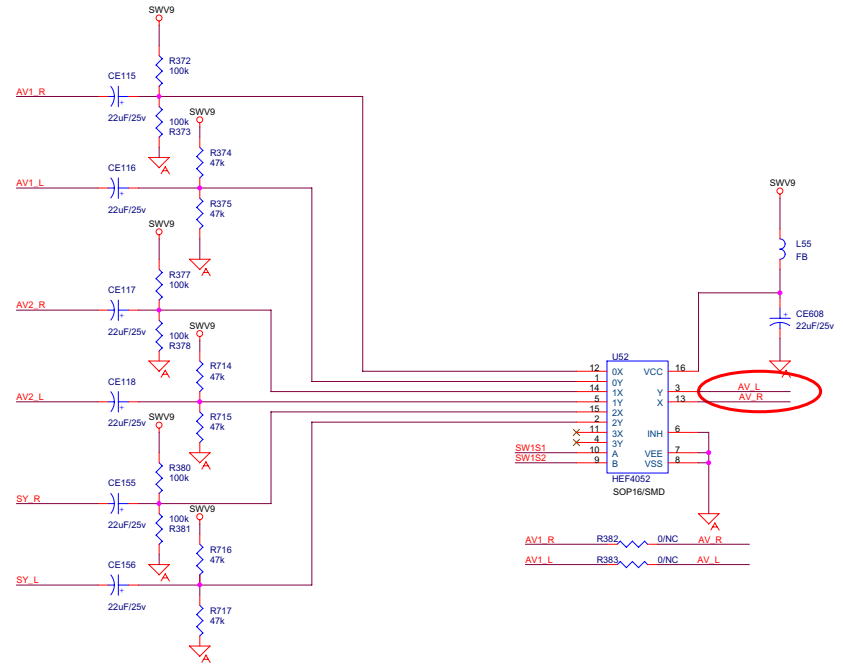
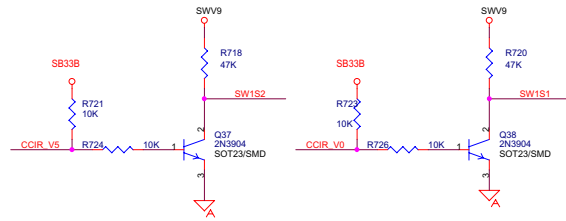
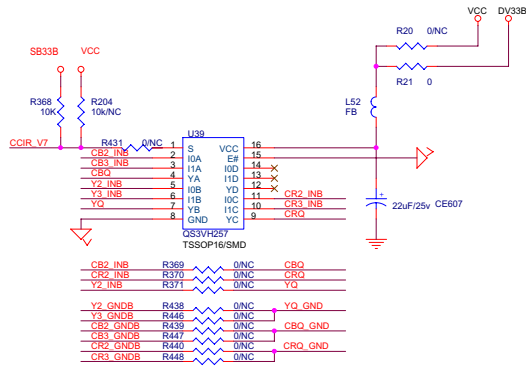

INPUT

| | | | |
|----------|----|----------|--------|
| GPIO7 | >> | GPIO7 | 3 |
| SCL | >> | SCL | 1,14 |
| SDA | >> | SDA | 1,14 |
| SDA_8202 | >> | SDA_8202 | 3,6,12 |
| SCL_8202 | >> | SCL_8202 | 3,6,12 |
| ADSDATA1 | >> | ADSDATA1 | 3 |
| ADCLK | >> | ADCLK | 3,16 |
| ADCLCK | >> | ADCLCK | 3,16 |
| ADIN | >> | ADIN | 3 |
| AV_R | >> | AV_R | 8 |
| AV_L | >> | AV_L | 8 |
| YPBR1_L | >> | YPBR1_L | 15 |
| YPBR1_R | >> | YPBR1_R | 15 |
| YPBR2_L | >> | YPBR2_L | 15 |
| YPBR2_R | >> | YPBR2_R | 15 |
| YPBR3_L | >> | YPBR3_L | 15 |
| YPBR3_R | >> | YPBR3_R | 15 |
| VGAR_IN | >> | VGAR_IN | 11 |
| VGAL_IN | >> | VGAL_IN | 11 |
| TESTP2 | >> | TESTP2 | 3 |
| AR | >> | AR | 3 |
| AL | >> | AL | 3 |
| MJ | >> | MJ | 17 |
| A_MUTE | >> | A_MUTE | 17,14 |
| 9V | >> | 9V | 17,14 |

OUTPUT

| | | | |
|----------|----|----------|------|
| AUSPR | >> | AUSPR | 16 |
| AUSPL | >> | AUSPR | 16 |
| AVR_OUT | >> | AVR_OUT | 15 |
| AVL_OUT | >> | AVL_OUT | 15 |
| CVBS_OUT | >> | CVBS_OUT | 6,15 |

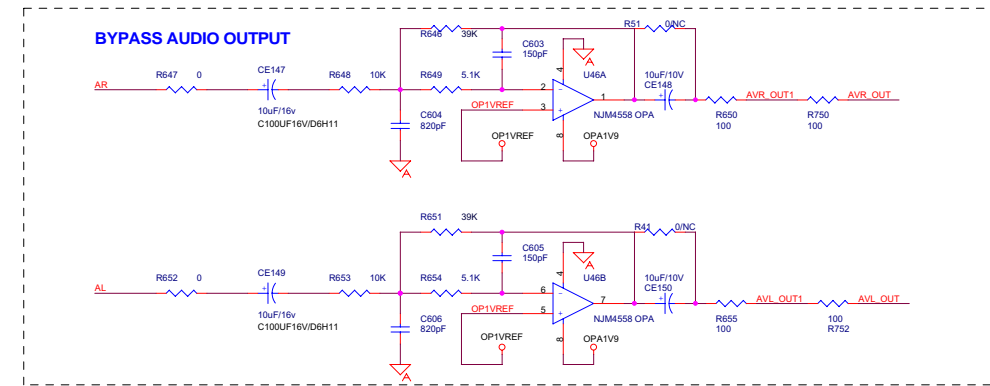
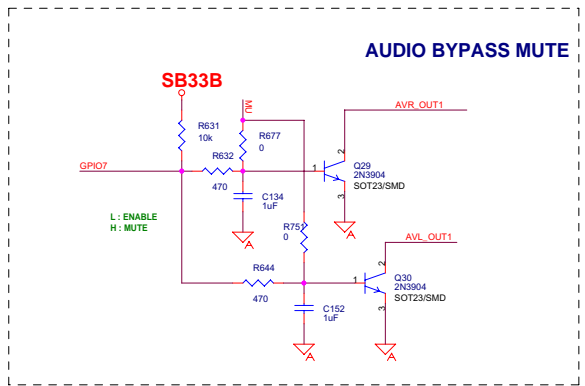
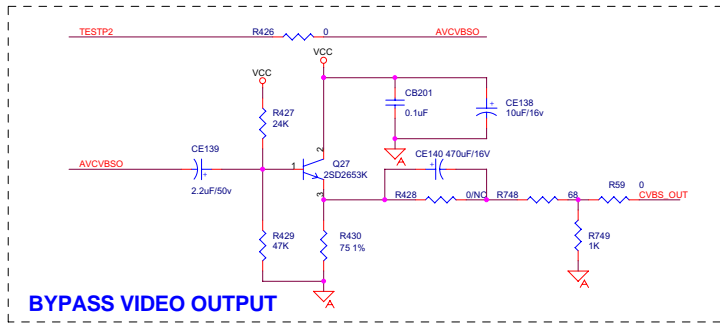
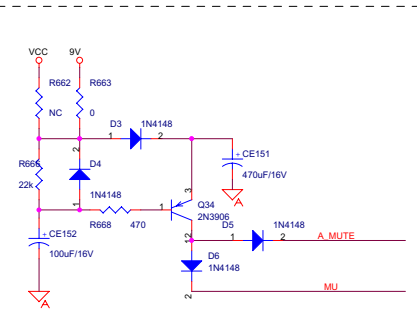
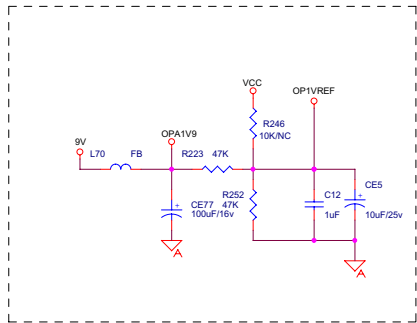
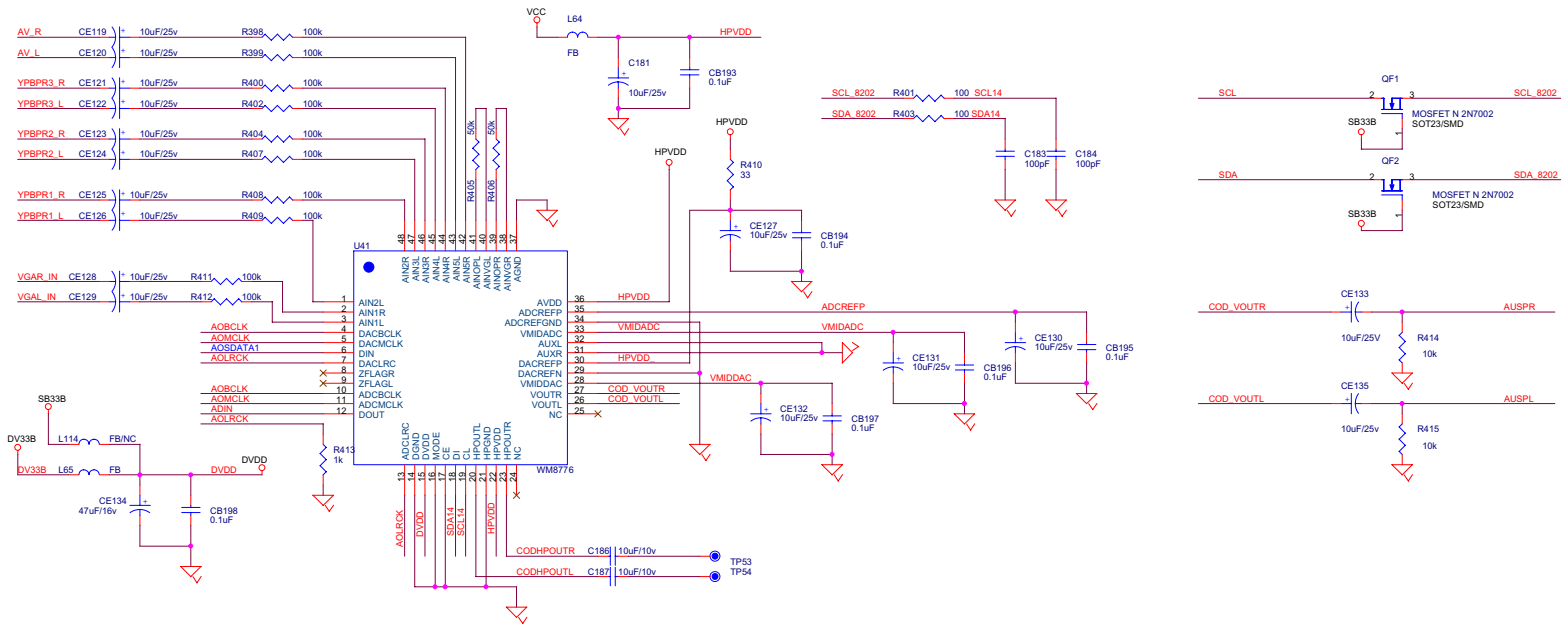

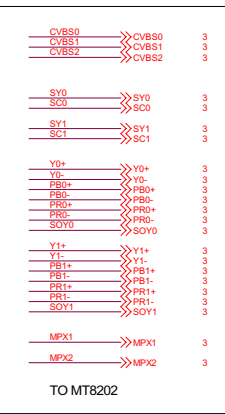

TO MT8202

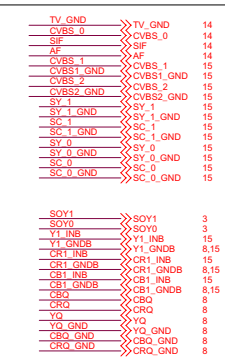

FROM AV BOARD

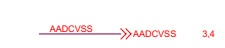

THIS PAGE NEARLY IC

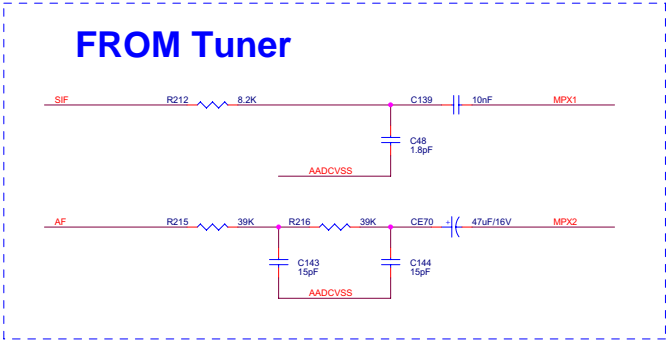
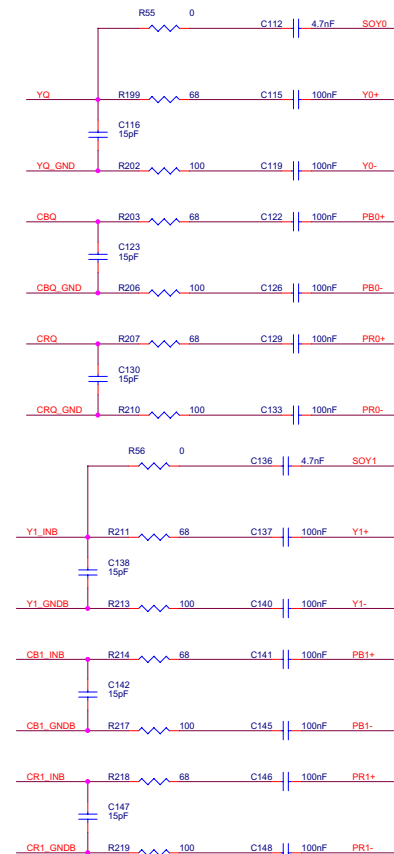
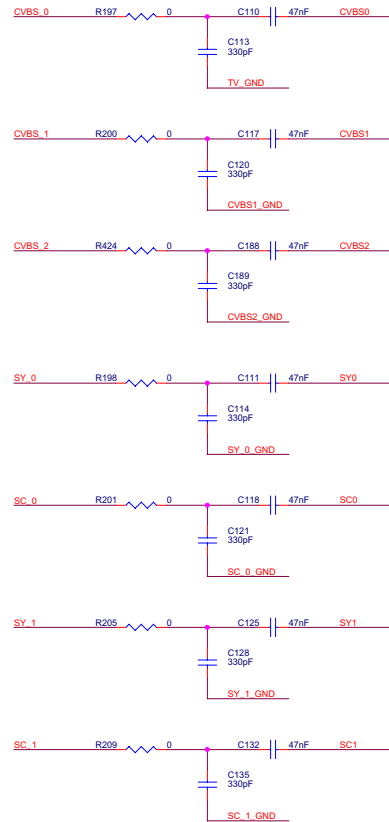

KAWA Confidential

ZhongShan KAWA Electronic Inc.

| | | | |
|--------------------------|----------------------------|--------------------|----------|
| AUDIO / VIDEO IN CIRCUIT | | | |
| Size | Document Number | Drawn: <Designer> | Rev |
| C | AKAI_MT8202_27US_LVDS_V0.0 | Checked: <Checker> | 1 |
| Date: | Monday, February 27, 2006 | Sheet | 10 of 17 |



VGA IN

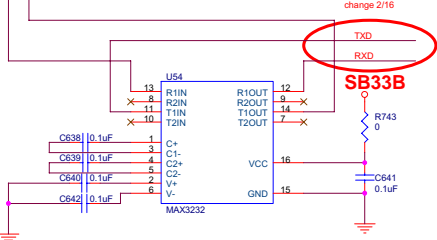
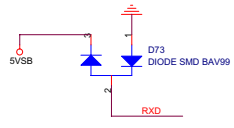
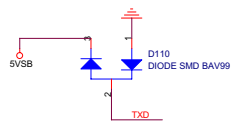
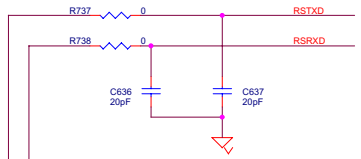
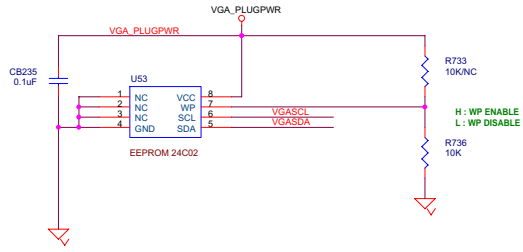
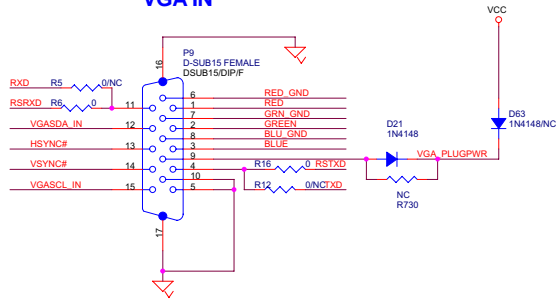

NEARLY VGA CON

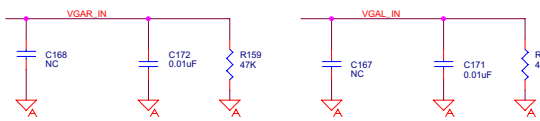
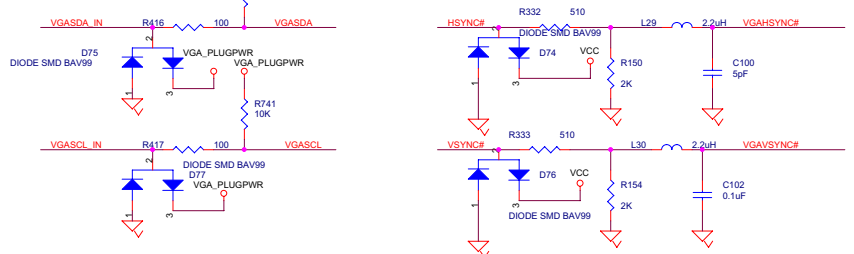
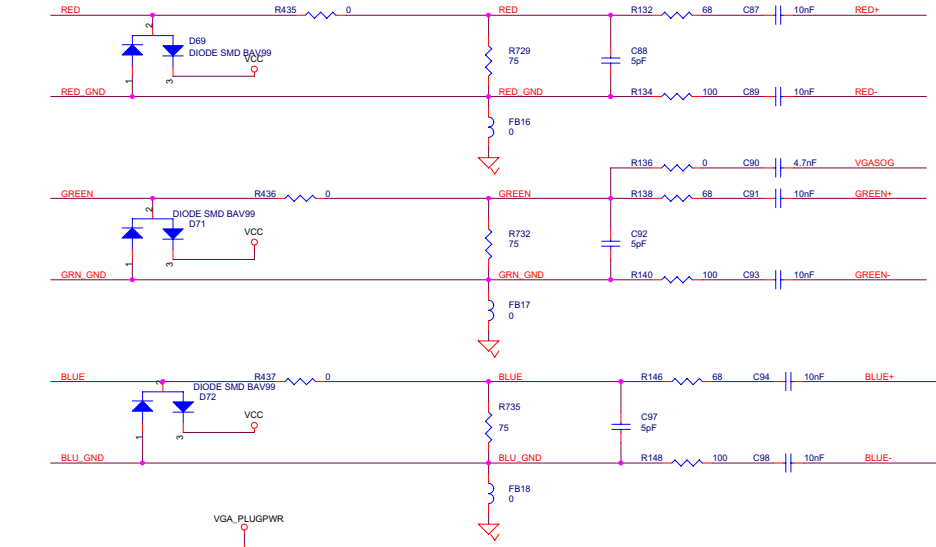

NEARLY 8202

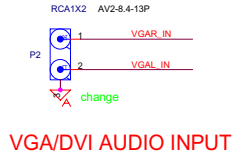

KAWA Confidential

| | | | |
|--------------------------------|----------------------------|--------------------|----------|
| ZhongShan KAWA Electronic Inc. | | | |
| VGA IN & PC AUDIO IN | | | |
| Size | Document Number | Drawn: <Designer> | Rev |
| C | AKAI_MT8202_27US_LVDS_V0.0 | Checked: <Checker> | 1 |
| Date: | Monday, February 27, 2006 | Sheet | 11 of 17 |

| | | |
|-----------|-----------|-------|
| GPIO0 | GPIO0 | 3 |
| GPIO2 | GPIO2 | 1,3 |
| CLK1+ | CLK1+ | 3 |
| CLK1- | CLK1- | 3 |
| AP0_7 | AP0_7 | 3 |
| AN0_6 | AN0_6 | 3 |
| LVDS_GND | LVDS_GND | 2,3,4 |
| LVDSVDD | LVDSVDD | 2,3,4 |
| CCIR_VCLK | CCIR_VCLK | 3 |
| CCIR_V4 | CCIR_V4 | 3 |
| FCLK | FCLK | 3 |
| FCMD | FCMD | 3 |
| FDAT | FDAT | 3 |
| SCL_8202 | SCL_8202 | 3,6,9 |
| SDA_8202 | SDA_8202 | 3,6,9 |
| RELAY_ON | RELAY_ON | 1 |
| VS_ON | VS_ON | 1 |
| 12V | 12V | 1,13 |

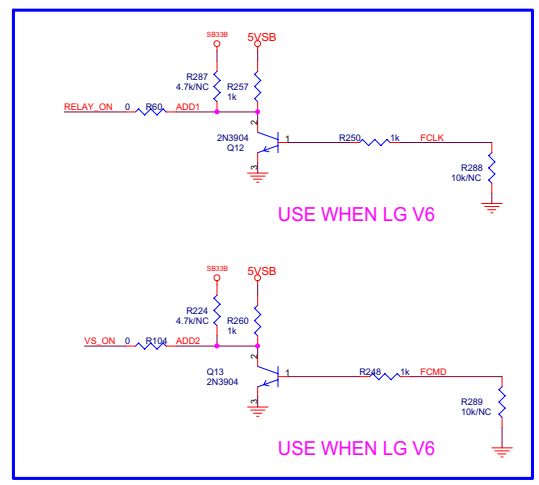
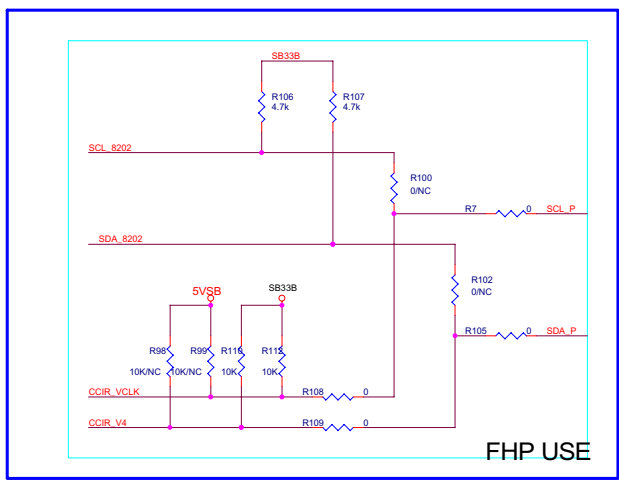
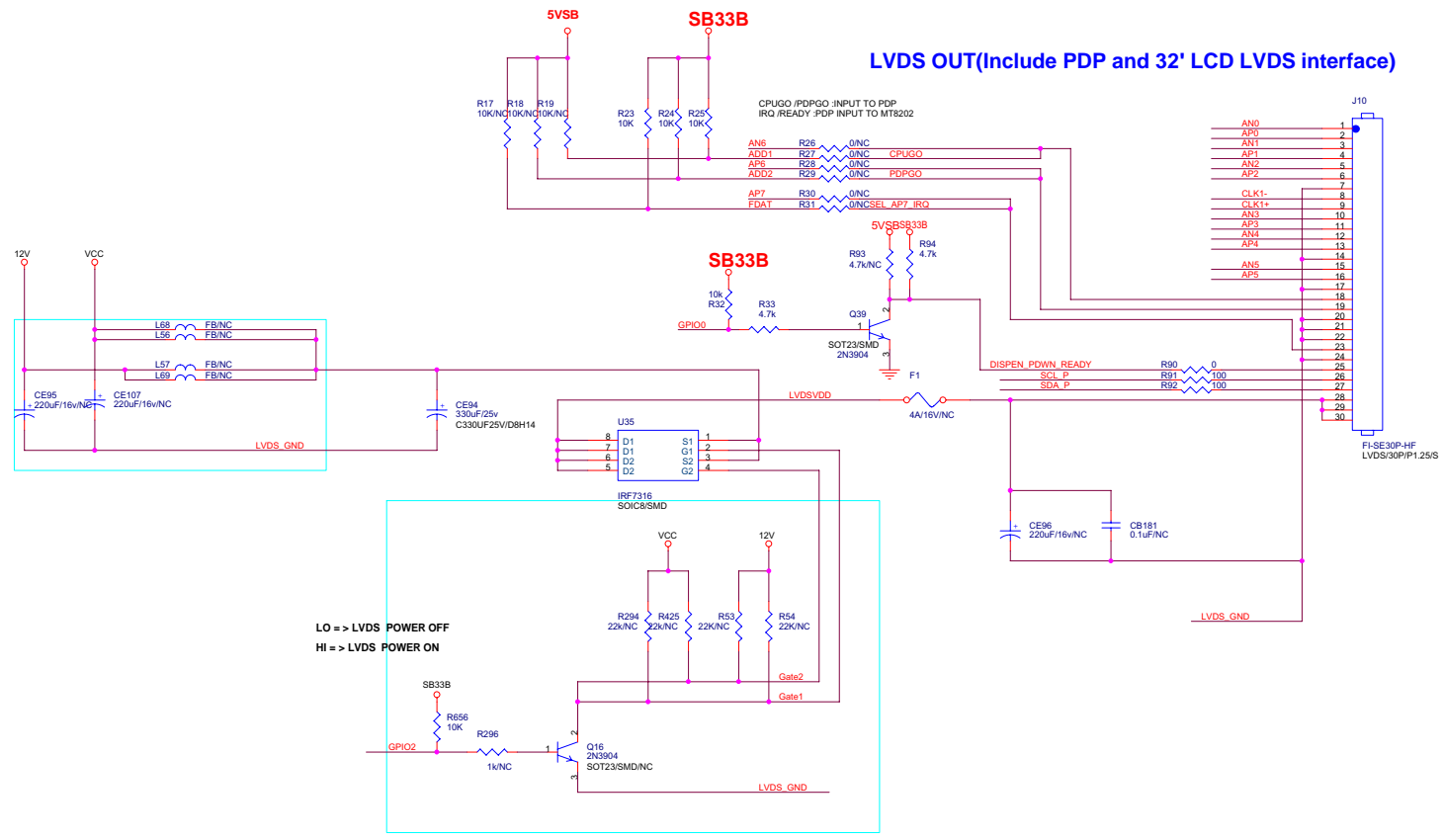

| | | |
|-----------|--------------|------|
| IR | >>>IR | 3,15 |
| GPIO10 | >>>GPIO10 | 3 |
| GPIO12 | >>>GPIO12 | 3 |
| GPIO13 | >>>GPIO13 | 3 |
| GPIO14 | >>>GPIO14 | 1,3 |
| PWM0 | >>>PWM0 | 3 |
| PWM1 | >>>PWM1 | 3 |
| 8202UP3_0 | >>>8202UP3_0 | 3 |
| GPIO14 | >>>GPIO14 | 1,3 |
| GPIO19 | >>>GPIO19 | 1,3 |
| VCLK | >>>VCLK | 3 |
| F_A21 | >>>F_A21 | 3 |
| CCIR_V2 | >>>CCIR_V2 | 3 |
| 12V | >>>12V | 1,12 |

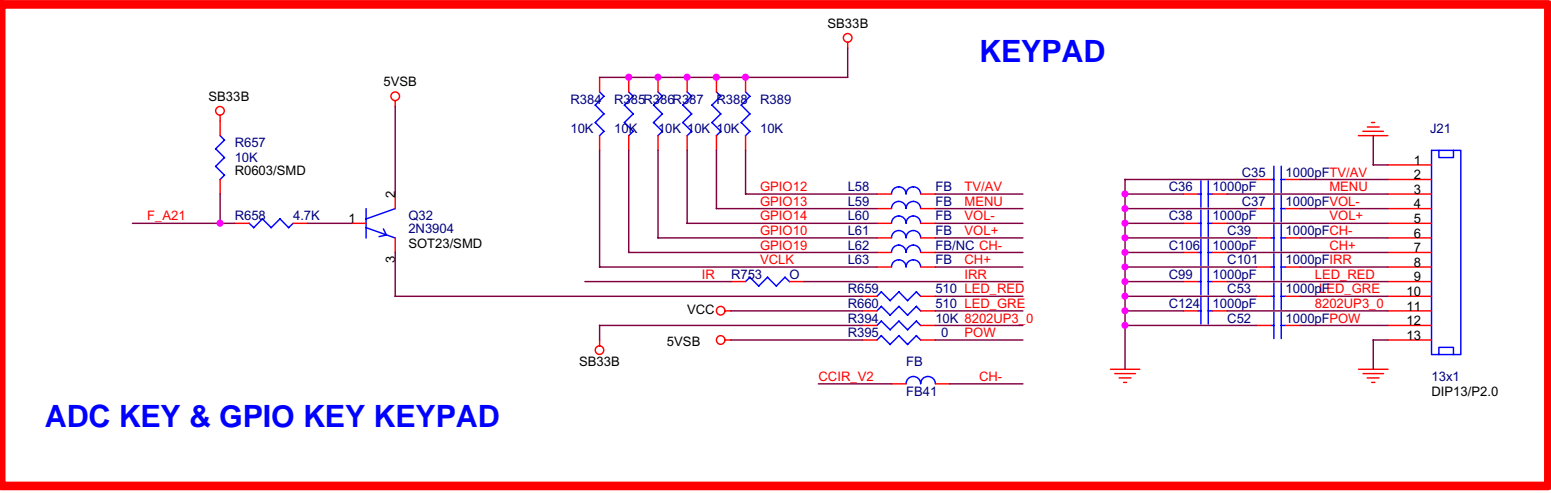

ADC KEY & GPIO KEY KEYPAD

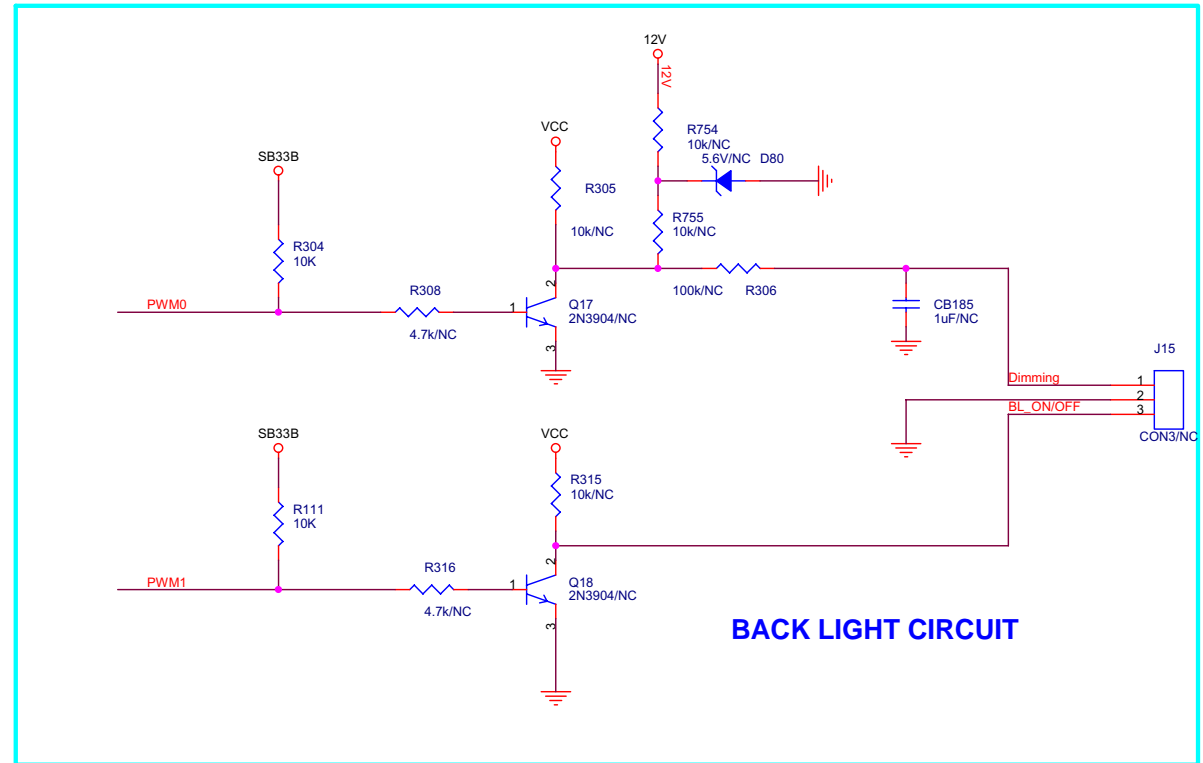

BACK LIGHT CIRCUIT

KAWA Confidential

| | | | |
|---------------------------------------|----------------------------|--------------------|----------|
| ZhongShan KAWA Electronic Inc. | | | |
| BACK LIGHT / KEYPAD | | | |
| Title | | | |
| Size | Document Number | Drawn: <Designer> | Rev |
| B | AKAI_MT8202_27US_LVDS_V0.0 | Checked: <Checker> | 1 |
| Date: | Monday, February 27, 2006 | Sheet | 13 of 17 |

SCL >> SCL 1,9
 SDA >> SDA 1,9
 CVBS_0 >> CVBS_0 10
 TV_GND >> TV_GND 10
 AF >> AF 10
 SIF >> SIF 10
 ADC_IN4 >> ADC_IN4 3
 9V >> 9V 1,7,9

TUNER SIF1NTSC 4.5MHz BPF

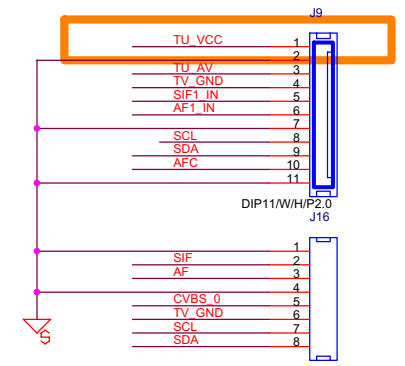
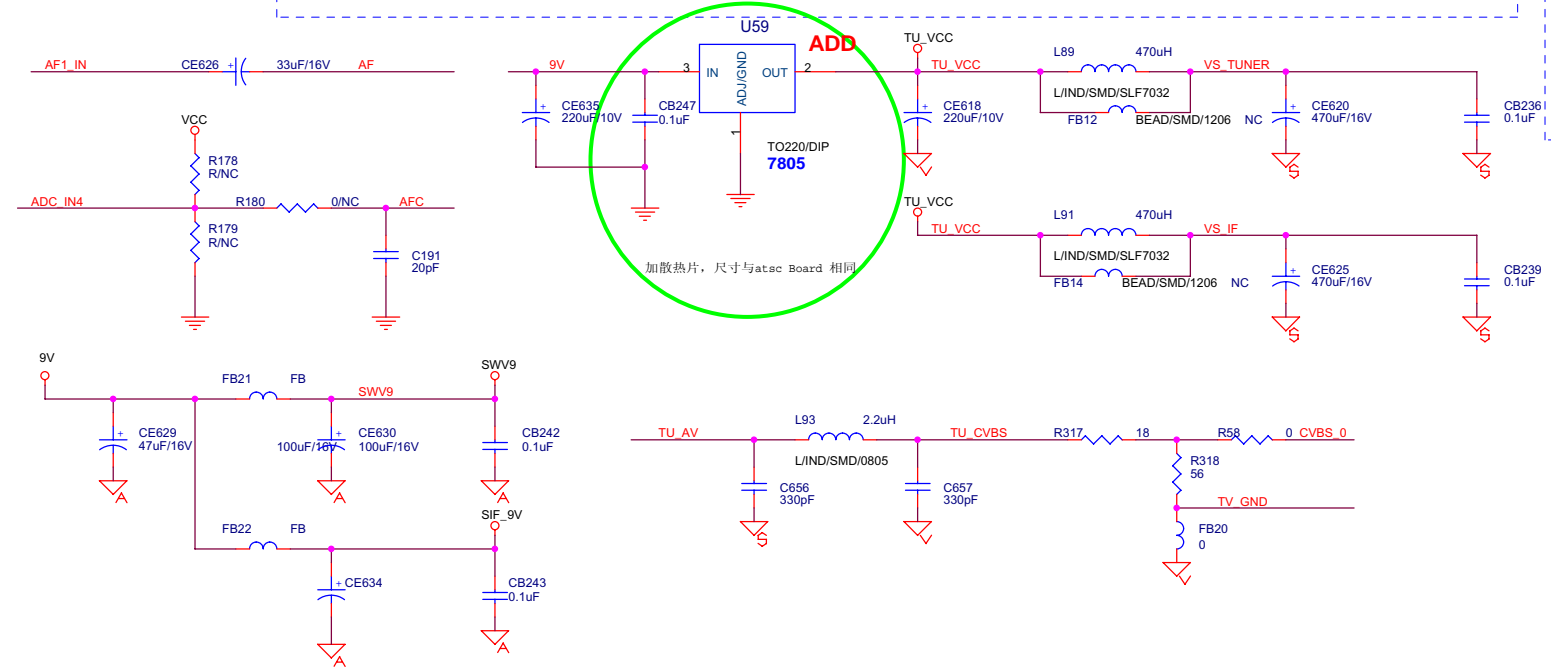
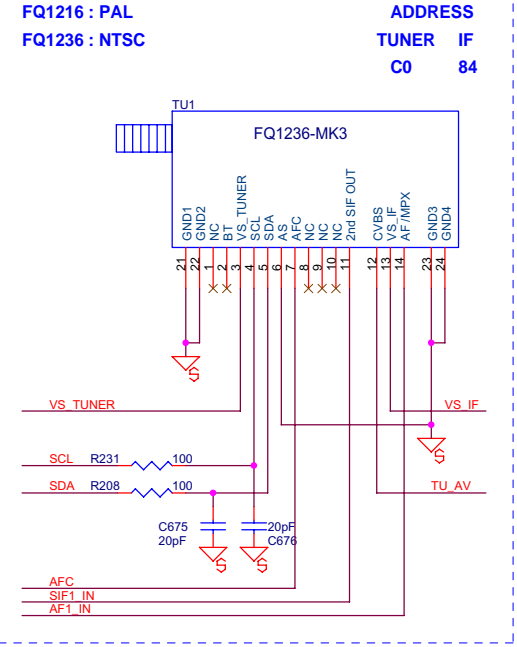
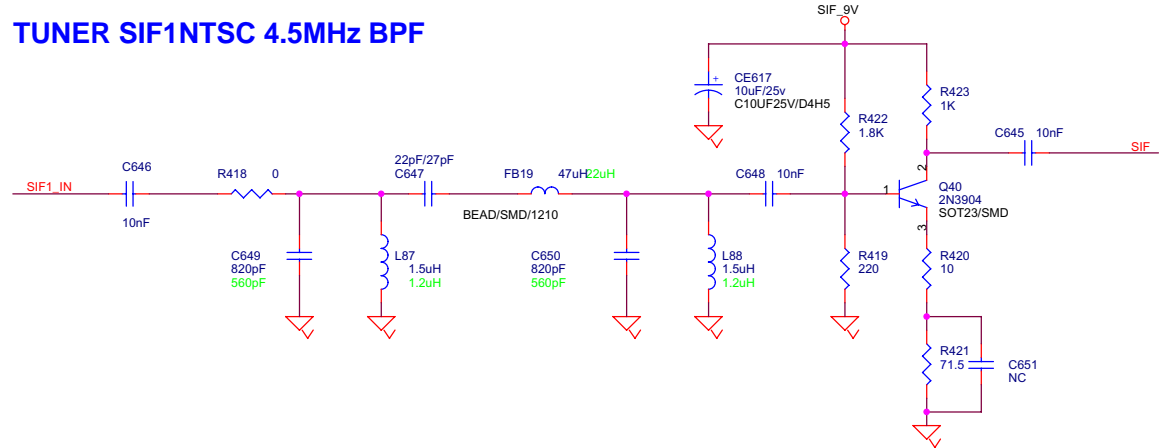

KAWA Confidential

| | | | |
|---------------------------------------|----------------------------|--------------------|--------|
| ZhongShan KAWA Electronic Inc. | | | |
| Title: TUNER IN | | | |
| Size: Document Number | AKAI_MT8202_27US_LVDS_V0.0 | Drawn: <Designer> | Rev: 1 |
| Cust: AKAI | | Checked: <Checker> | |
| Date: Monday, February 27, 2006 | | Sheet: 14 | of 17 |

AV /YC VIDEO IN

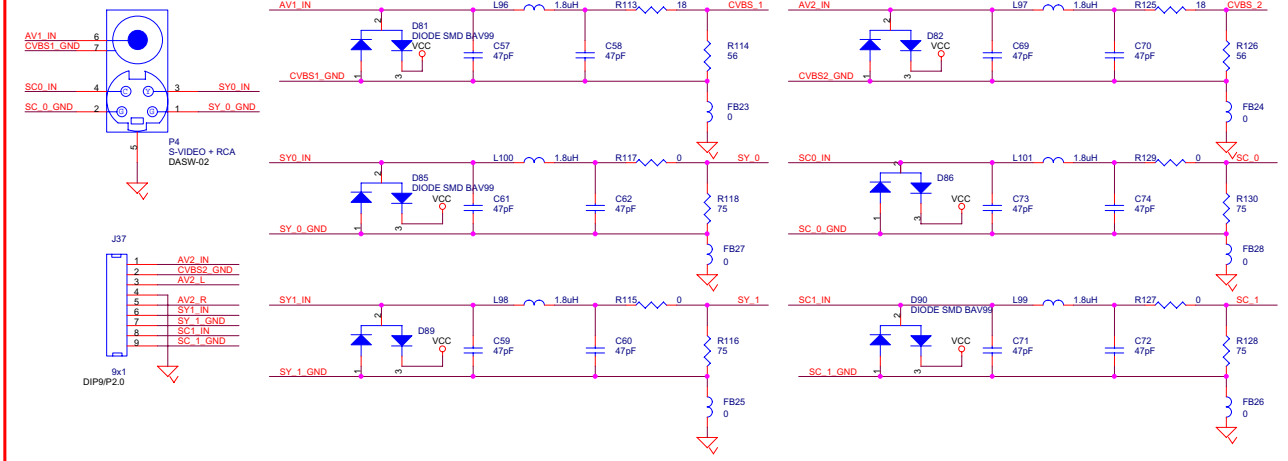

AV /YC AUDIO IN

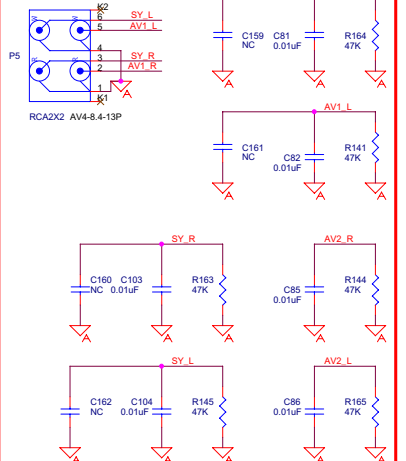

| | | |
|-----------|-----------|------|
| GPIO1 | GPIO1 | 3 |
| IR | IR | 3,13 |
| SY_1 | SY_1 | 10 |
| SY_1_GND | SY_1_GND | 10 |
| SC_1 | SC_1 | 10 |
| SC_1_GND | SC_1_GND | 10 |
| SY_0 | SY_0 | 10 |
| SY_0_GND | SY_0_GND | 10 |
| SC_0 | SC_0 | 10 |
| SC_0_GND | SC_0_GND | 10 |
| CVBS1 | CVBS1 | 10 |
| CVBS1_GND | CVBS1_GND | 10 |
| CVBS2 | CVBS2 | 10 |
| CVBS2_GND | CVBS2_GND | 10 |
| SPOUTR | SPOUTR | 16 |
| AVR_OUT | AVR_OUT | 9 |
| AVL_OUT | AVL_OUT | 9 |
| CVBS_OUT | CVBS_OUT | 6,9 |
| AV1_R | AV1_R | 8 |
| AV1_L | AV1_L | 8 |
| AV2_R | AV2_R | 8 |
| AV2_L | AV2_L | 8 |
| SY_R | SY_R | 8 |
| SY_L | SY_L | 8 |
| YPBPR1_L | YPBPR1_L | 9 |
| YPBPR1_R | YPBPR1_R | 9 |
| YPBPR2_L | YPBPR2_L | 9 |
| YPBPR2_R | YPBPR2_R | 9 |
| YPBPR3_L | YPBPR3_L | 9 |
| YPBPR3_R | YPBPR3_R | 9 |
| Y1_INB | Y1_INB | 10 |
| Y1_GNDB | Y1_GNDB | 10 |
| CB1_INB | CB1_INB | 10 |
| CB1_GNDB | CB1_GNDB | 8,10 |
| CR1_INB | CR1_INB | 10 |
| CR1_GNDB | CR1_GNDB | 8,10 |
| Y2_INB | Y2_INB | 8 |
| Y2_GNDB | Y2_GNDB | 8,10 |
| CB2_INB | CB2_INB | 8 |
| CB2_GNDB | CB2_GNDB | 8,10 |
| CR2_INB | CR2_INB | 8,10 |
| CR2_GNDB | CR2_GNDB | 8,10 |
| Y3_INB | Y3_INB | 8 |
| Y3_GNDB | Y3_GNDB | 8 |
| CB3_INB | CB3_INB | 8 |
| CB3_GNDB | CB3_GNDB | 8 |
| CR3_INB | CR3_INB | 8 |
| CR3_GNDB | CR3_GNDB | 8 |
| GNDV | GNDV | |
| GNDV | GNDV | |

AV VIDEO/AUDIO OUT.

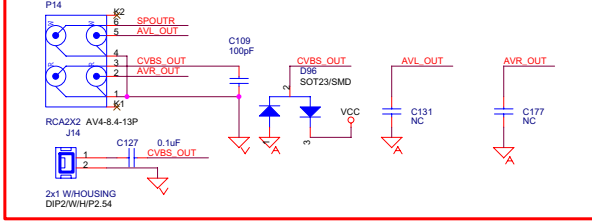

YPBPR AUDIO IN.

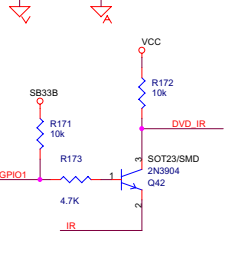
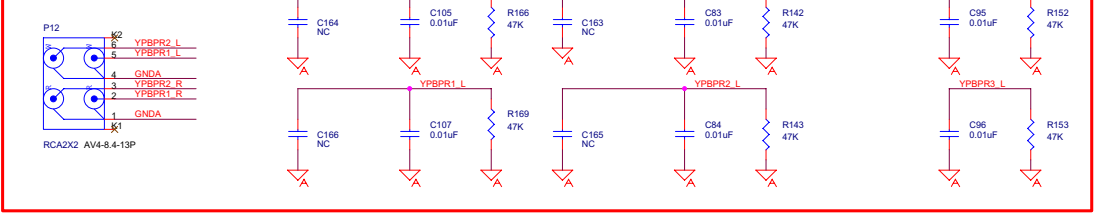

YPBPR VIDEO IN.

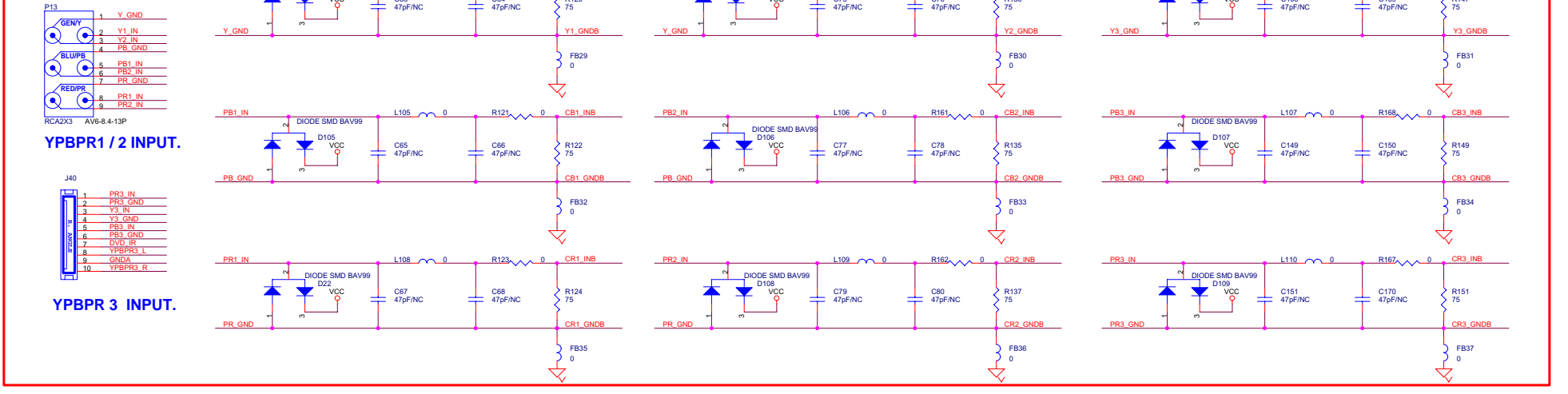

| | | | |
|---------------------------------------|----------------------------|---------------------|----------|
| ZhongShan KAWA Electronic Inc. | | | |
| AV IN | | | |
| File | Document Number | Drawn: <Designers> | Rev 1 |
| C | AKAL_MT8202_27US_LVDS_V0.0 | Checked: <Checkers> | |
| Date: | Monday, February 27, 2006 | Sheet | 15 of 17 |

KAWA Confidential

AOSDATA2 >>> AOSDATA2 3
 AOMCLK >>> AOMCLK 3,9
 AOBCLK >>> AOBCLK 3,9
 AOLRCK >>> AOLRCK 3,9
 MU >>> MU 9
 SPOUTR >>> SPOUTR 15
 AUSPR >>> AUSPR 9
 AUSPL >>> AUSPL 9
 OPOUTR >>> OPOUTR 17
 OPOUTL >>> OPOUTL 17
 A_MUTE >>> A_MUTE 9,17

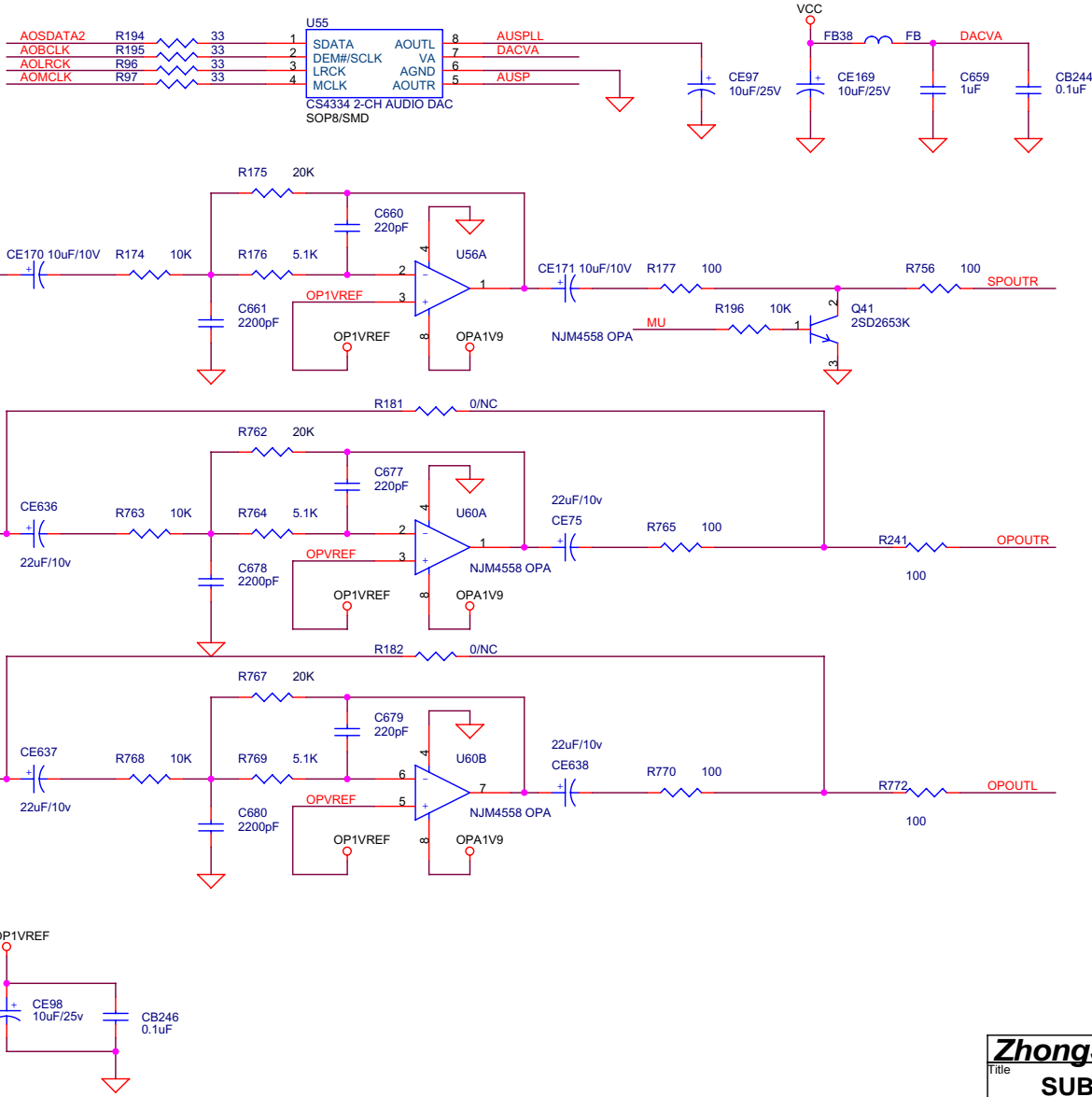

GPIO DECRPTION

- UP3_4 : SW SCL
- UP3_5 : SW SDA
- ERO0/UP3_0 :KEYPAD POWER
- ERO1/UP3_1 : MAIN POWER SWITCH
- VCLK : KEPAD CH+
- GPIO19 : KEPAD CH-
- DE/GPIO : DVD IR
- CCIR_CLK : PDP USE
- CCIR_V4 : PDP USE
- GPIO0 : PDP USE
- GPIO1 : NO USE
- GPIO2 : LVDS POWER SW
- GPIO3 : DTV POWER CONTROL
- GPIO4 : EEPROM WRITE PROTECT
- GPIO5/TXD : 2nd UART FOR MT5351
- GPIO6/RXD : 2nd UART FOR MT5351
- GPIO7 : AUDIO BYPASS MUTE CONTROL
- GPIO8 : SPEAKER SWITCH
- GPIO9 : AUDIO MUTE
- GPIO10 : Indicates active video at HDMI port
- GPIO11 : DVD POWER CONTROL
- GPIO12 : AV SWITCH
- GPIO13 : HDMI Hot Plug Detect
- GPIO14 : NO USE
- GPIO[15..18] : FOR DVD CONTROL
- GPIO/PWM0 : DIMMING
- GPIO/PWM1 : BACKLIGHT ON/OFF
- OUT_27Mhz/GPIO : HDMI CRYSTAL
- SDA1 : TO MT5351 I/F REQUEST
- SCL1 : TO MT5351 I/F READY
- F_A21 : KEYPAD(LED RED)
- ADCIN0 : KEYPAD
- ADCIN3:PDP 5VD DETECT
- ADCIN4:FOR TUNER AFC
- CCIR_V[0-3] : KEYPAD
- CCIR_V5 : AUDIO SWITCH
- CCIR_V6 : RESET DTV
- CCIR_V7 : YBPBR VIDEO SWITCH

KAWA Confidential

| | | | |
|---------------------------------------|----------------------------|--------------------|----------|
| ZhongShan KAWA Electronic Inc. | | | |
| Title | | | |
| SUB WOOFER | | | |
| Size | Document Number | Drawn: <Designer> | Rev |
| B | AKAI_MT8202_27US_LVDS_V0.0 | Checked: <Checker> | 1 |
| Date: | Monday, February 27, 2006 | Sheet | 16 of 17 |

GPIO8 >> GPIO8 3
 GPIO9 >> GPIO9 3
 AUSPR >> AUSPR 9,16
 AUSPL >> AUSPL 9,16
 A_MUTE >> A_MUTE 9
 OPOUTR >> OPOUTR 16
 OPOUTL >> OPOUTL 16

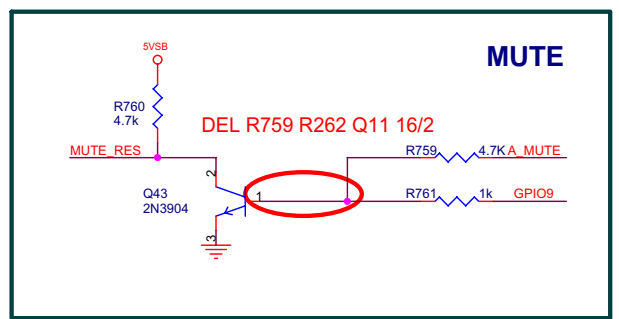
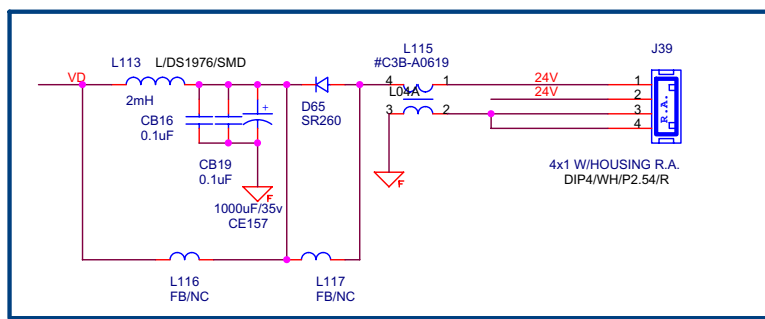
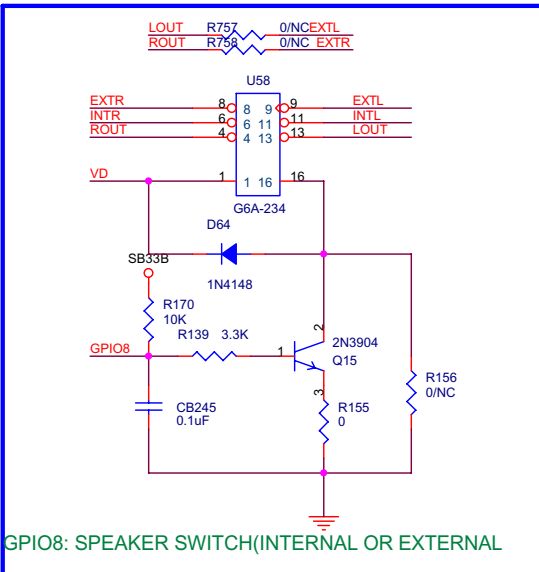
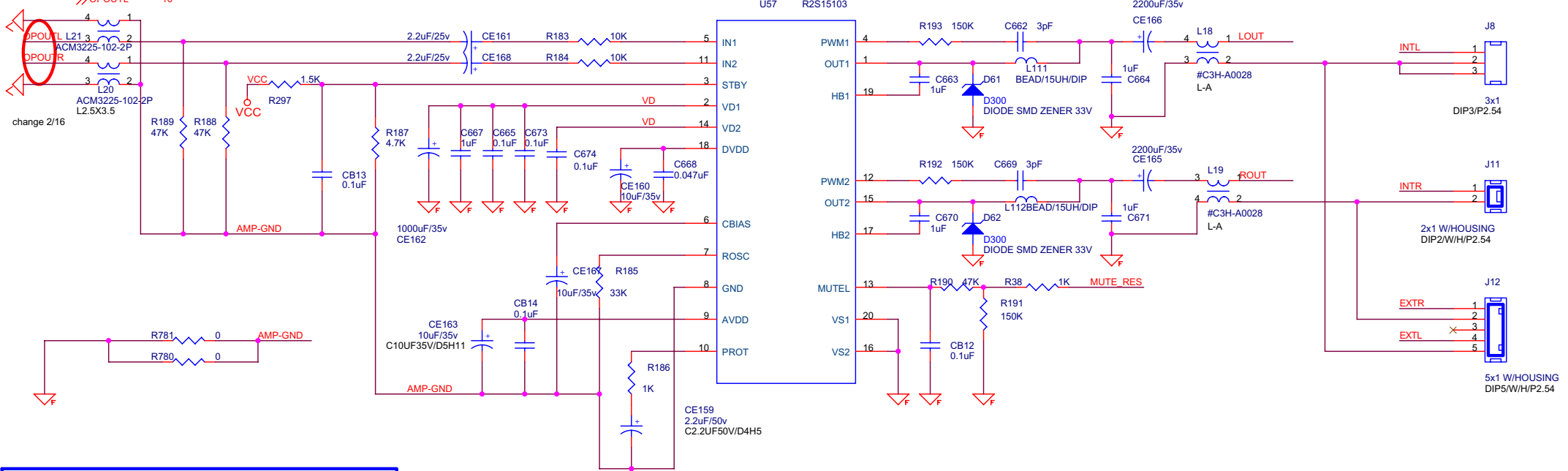

KAWA Confidential

| | | | |
|---------------------------------------|----------------------------------------------------|--------------------|-------|
| ZhongShan KAWA Electronic Inc. | | | |
| Title: AUDIO Amplifier | | | |
| Size B | Document Number: AKAI_MT8202_27US_LVDS_V0.0 | Drawn: <Designer> | Rev 1 |
| Date: Monday, February 27, 2006 | | Checked: <Checker> | |
| | | Sheet 17 of 17 | |

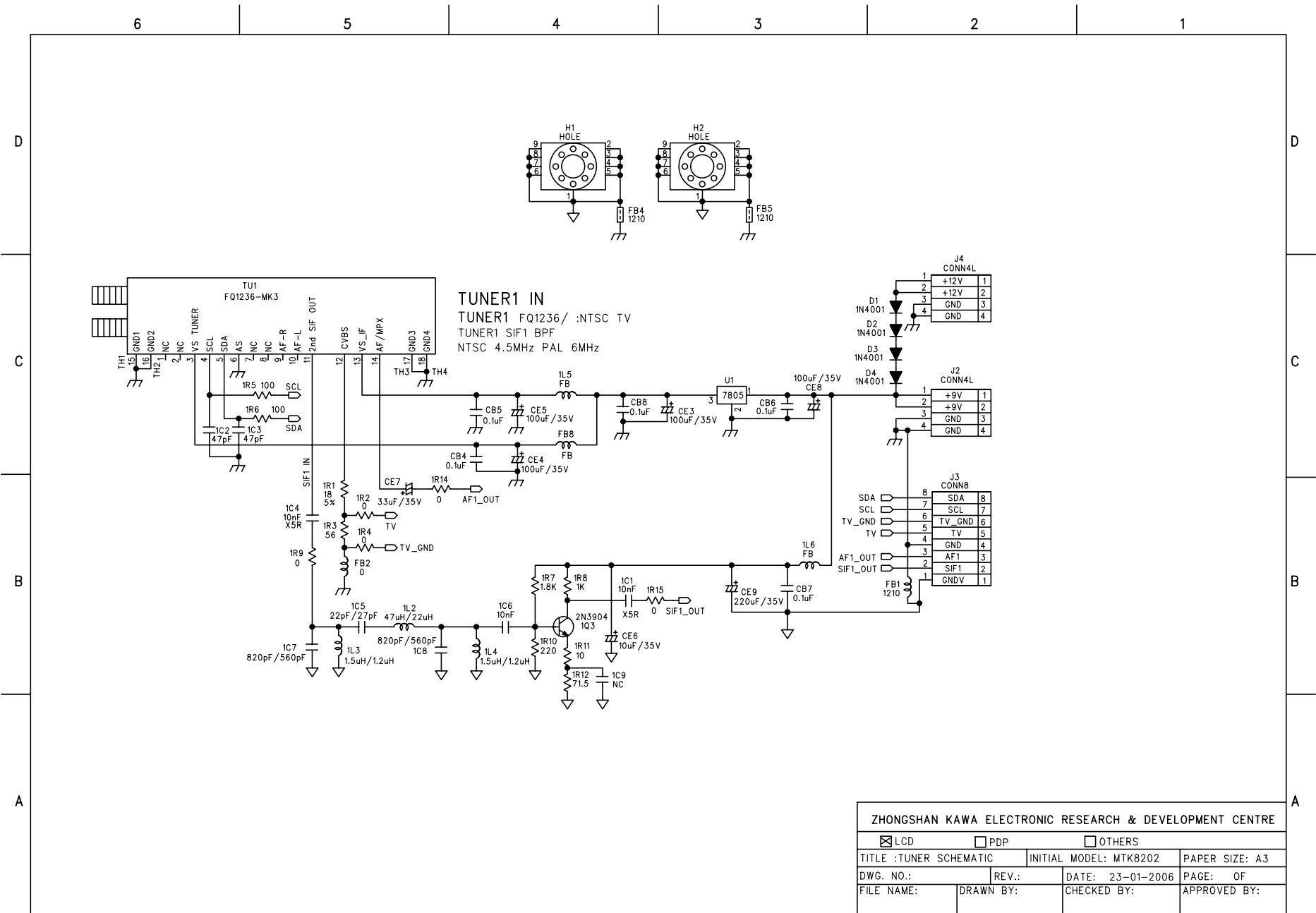

| | | | |
|---------------------------------------------------------|------------------------------|---------------------------------|--------------|
| ZHONGSHAN KAWA ELECTRONIC RESEARCH & DEVELOPMENT CENTRE | | | |
| <input checked="" type="checkbox"/> LCD | <input type="checkbox"/> PDP | <input type="checkbox"/> OTHERS | |
| TITLE : TUNER SCHEMATIC | INITIAL MODEL: MTK8202 | PAPER SIZE: A3 | |
| DWG. NO.: | REV.: | DATE: 23-01-2006 | PAGE: 0F |
| FILE NAME: | DRAWN BY: | CHECKED BY: | APPROVED BY: |

MT5111 / MT5351 REFERENCE DESIGN - 4 LAYERS

| Rev | History | P# | DATE |
|-------|-------------------------------------------|----|------------|
| RA-V1 | INITIAL VERSION | | 2005/06/15 |
| RA-V2 | ADDED AUDIO SWITCH / REFINE POWER CIRCUIT | | 2005/07/14 |
| | | | |
| | | | |
| | | | |

01. INDEX AND INTERFACE
02. POWER
03. TUNER
04. MT5111 ASIC
05. MT5351 ASIC
06. MT5351 PERIPHERAL
07. DDR MEMORY
08. NOR FLASH / JTAG / UART

NS : NON-STUFF

| NAME | TYPE | DEVICE |
|-----------|------------|---------------------|
| +12V | POWER +12V | POWER SUPPLY |
| +5V | POWER +5V | POWER SUPPLY |
| +5V_tuner | POWER +5V | TUNER POWER |
| DV33_DM | POWER +3V3 | MT5111 POWER |
| DV18 | POWER +1V8 | MT5111 POWER |
| DV33 | POWER +3V3 | MT5351 POWER |
| AV33 | POWER +3V3 | MT5351 ANALOG POWER |
| DV25 | POWER +2V5 | MT5351 DDR POWER |
| DV12 | POWER +1V2 | MT5351 POWER |
| GND | GROUND | GROUND |

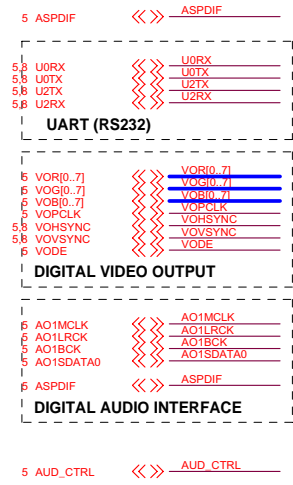
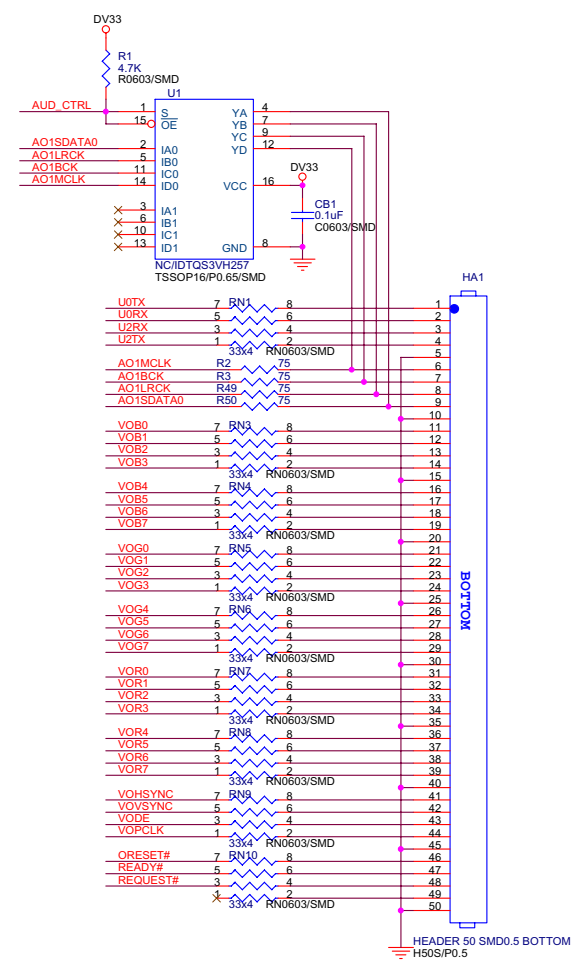
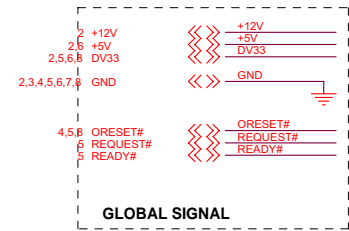
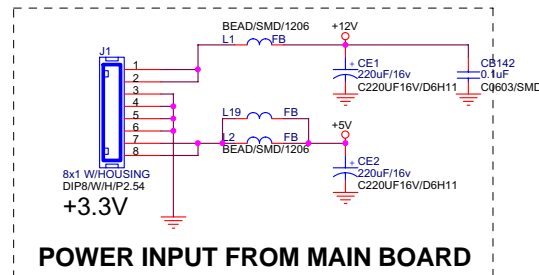

DIGITAL OUTPUT

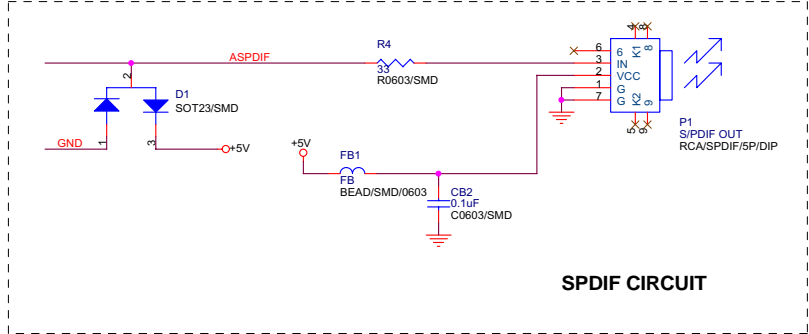

SPDIF CIRCUIT

9V

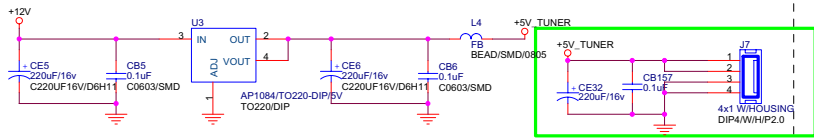

POWER SUPPLY +5V FOR TUNER

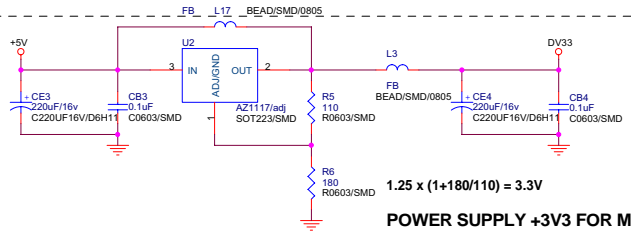

1.25 x (1+180/110) = 3.3V
POWER SUPPLY +3V3 FOR MT5351

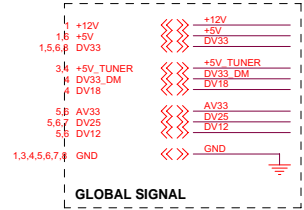

GLOBAL SIGNAL

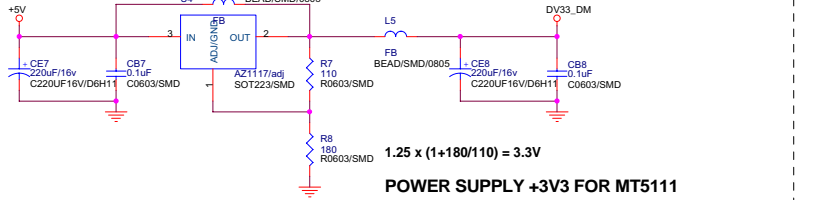

1.25 x (1+180/110) = 3.3V
POWER SUPPLY +3V3 FOR MT5111

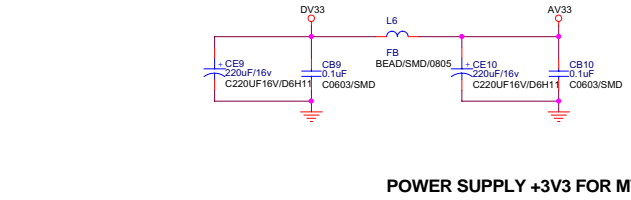

POWER SUPPLY +3V3 FOR MT5351 (ANALOG)

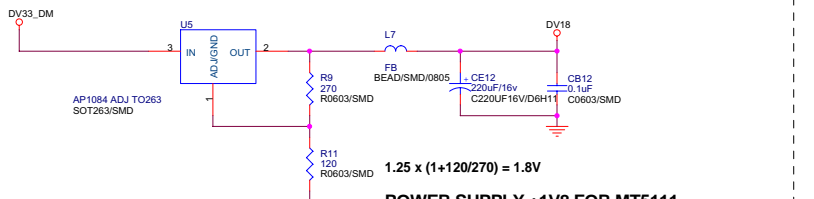

1.25 x (1+120/270) = 1.8V
POWER SUPPLY +1V8 FOR MT5111

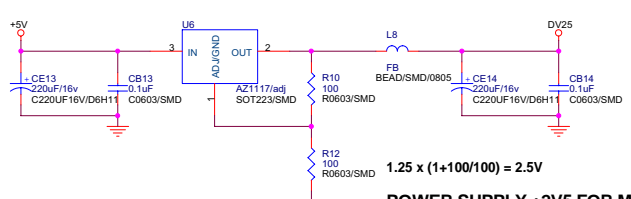

1.25 x (1+100/100) = 2.5V
POWER SUPPLY +2V5 FOR MT5351 AND DDR

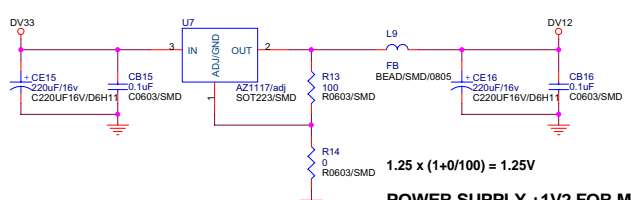
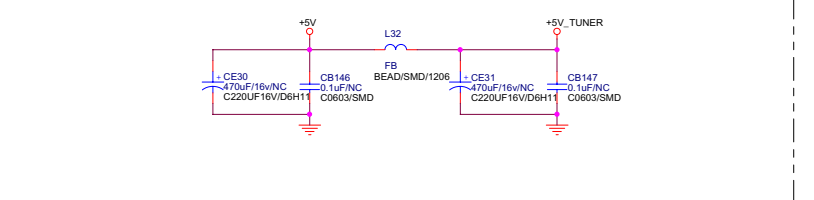

1.25 x (1+0/100) = 1.25V
POWER SUPPLY +1V2 FOR MT5351

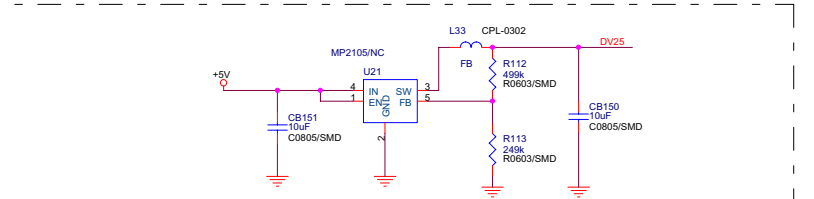

Compatible With U6

MediaTek Confidential

| | | | |
|--------|---------------------------------------------------------------------------------------------------------------|--------------|--------|
| | MediaTek Inc. No. 1-2, Innovation Rd 1, SBIP, Hsin-Chu City 300 TEL: (03)567-0766 FAX: (03)578-7610 | | |
| | POWER | | |
| Size | Document Number | Drawn | Rev |
| Custpm | MT5351RA-V2 | TwinSan Chan | 1 |
| Date: | Monday, December 12, 2005 | Sheet | 2 of 8 |

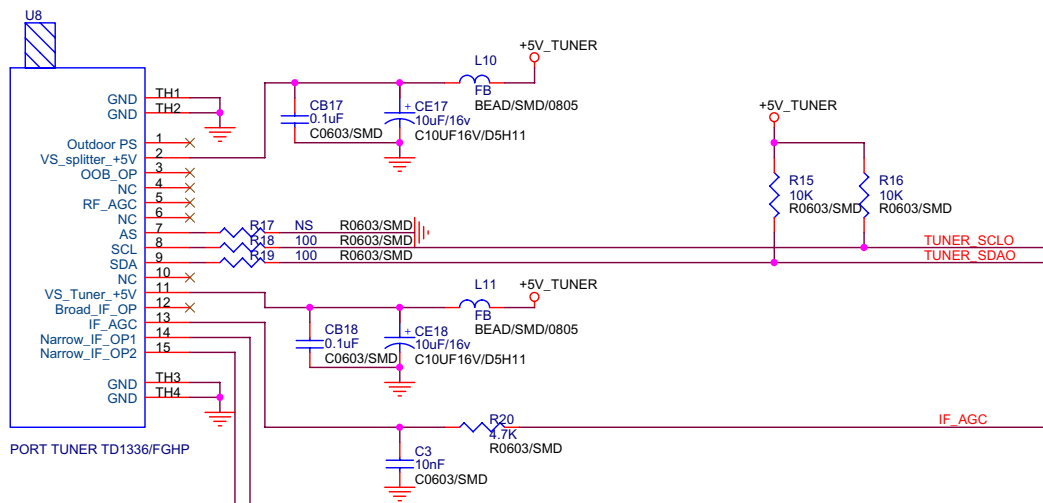

PORT TUNER TD1336/FGHP

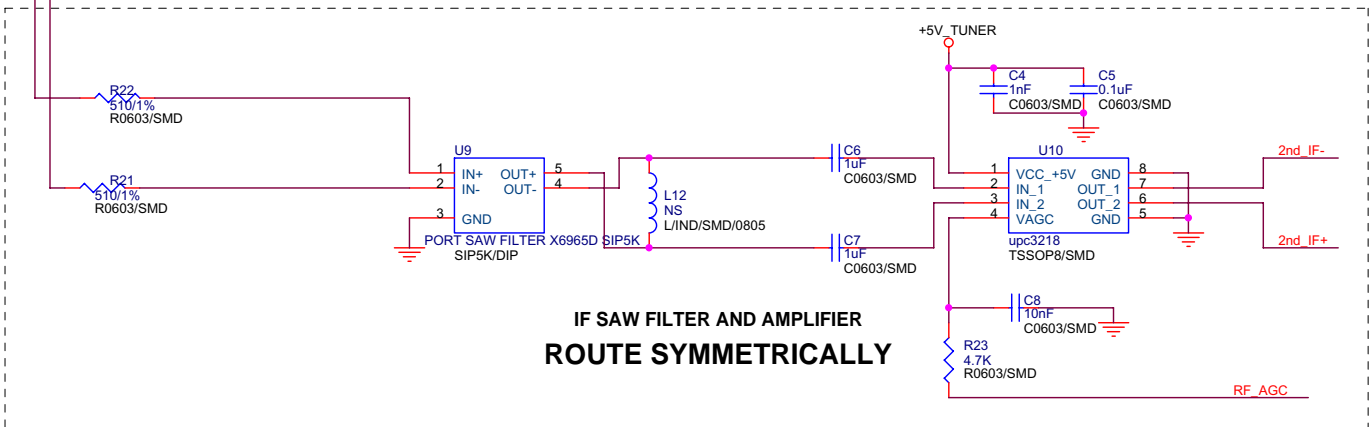

**IF SAW FILTER AND AMPLIFIER
ROUTE SYMMETRICALLY**

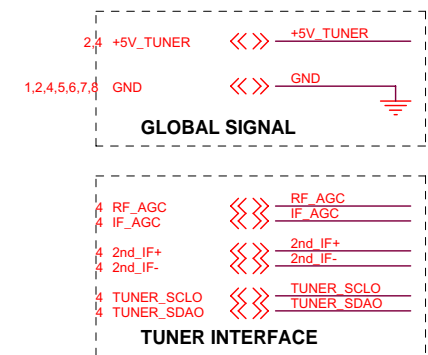

MediaTek Confidential



MediaTek Inc. No.1-2, Innovation Rd 1, SBIP, Hsin-Chu City 300
TEL: (03)567-0766 FAX: (03)578-7610

| | | | |
|-----------------------|---------------------------------------|---------------------------------|----------|
| Title TUNER | | Drawn TwinSon Chan | Rev 1 |
| Size Custom | Document Number MT5351RA-V2 | Date: Monday, December 12, 2005 | |
| Sheet 3 of 8 | | Date: Monday, December 12, 2005 | |

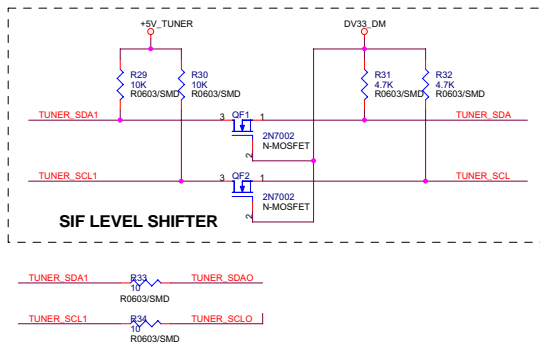
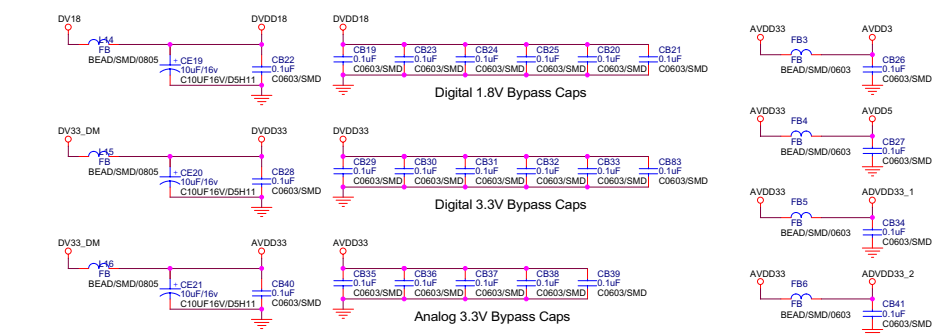
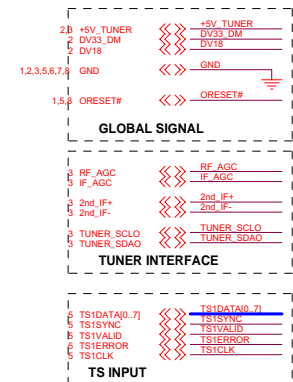
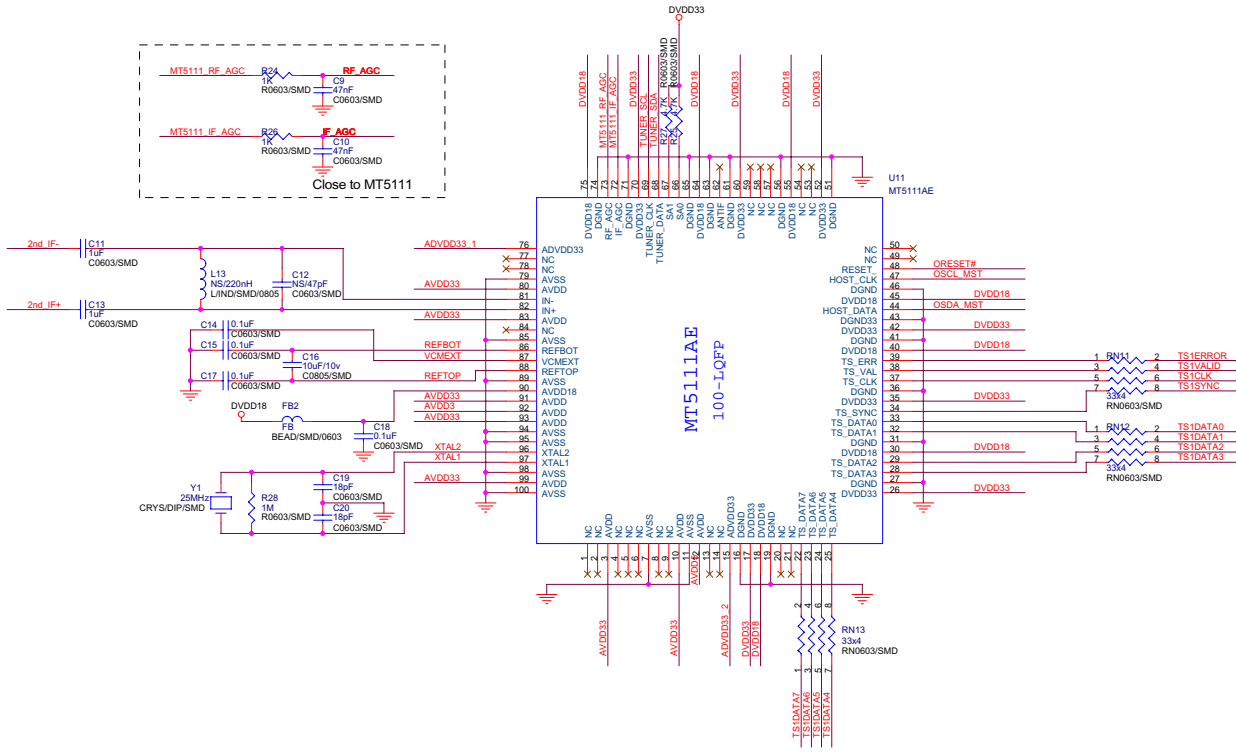
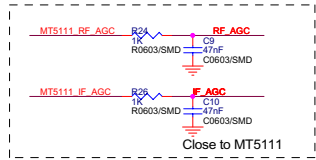

MT5351

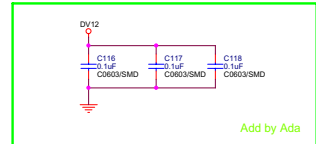
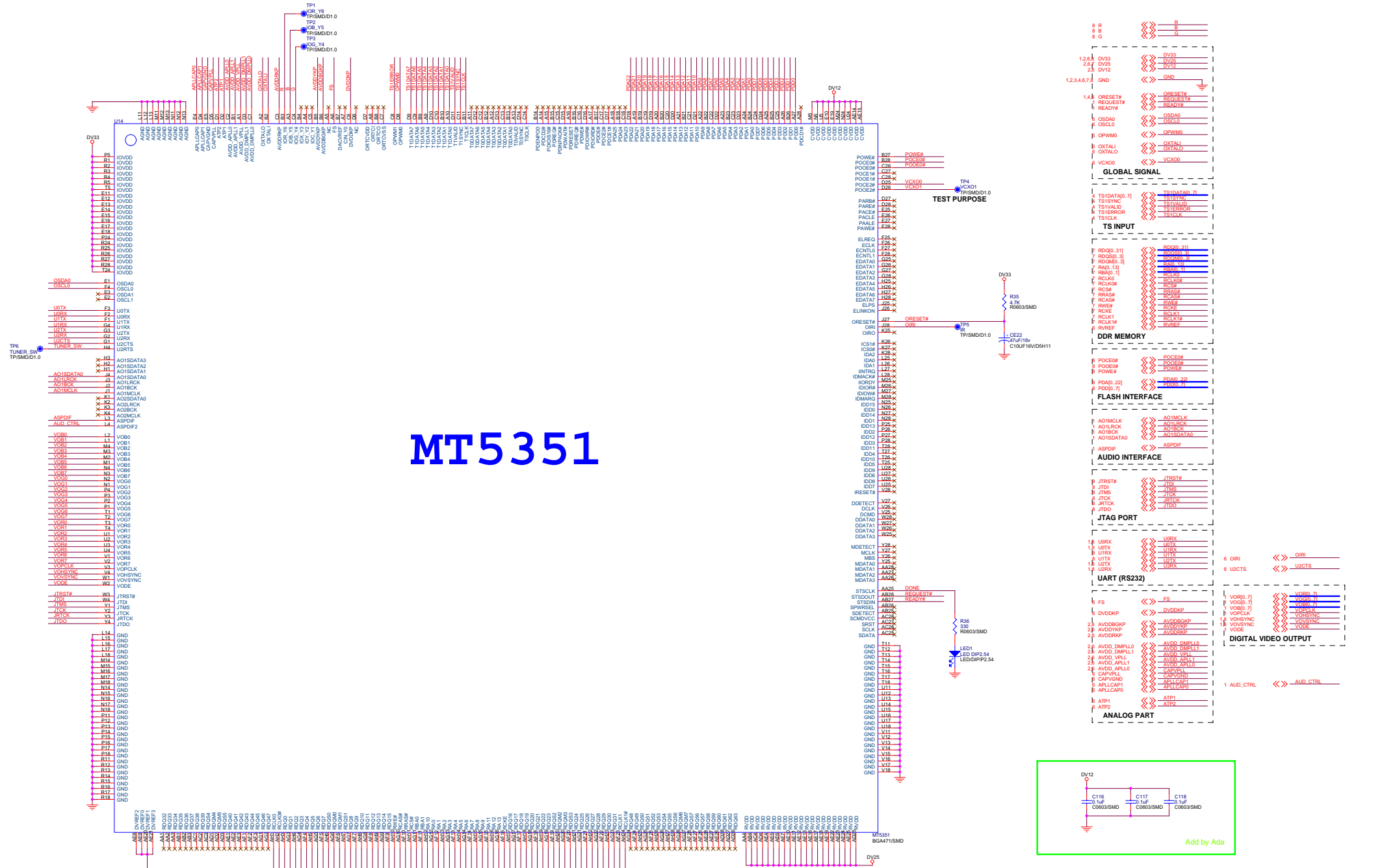

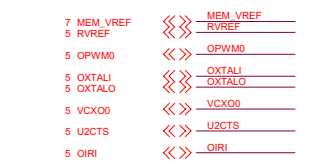
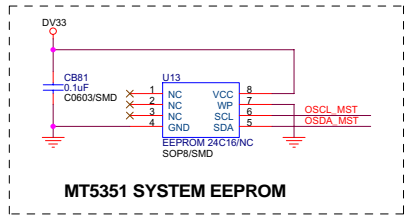
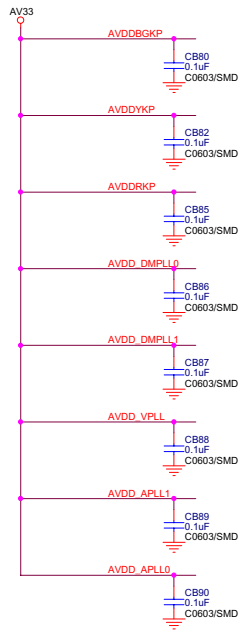
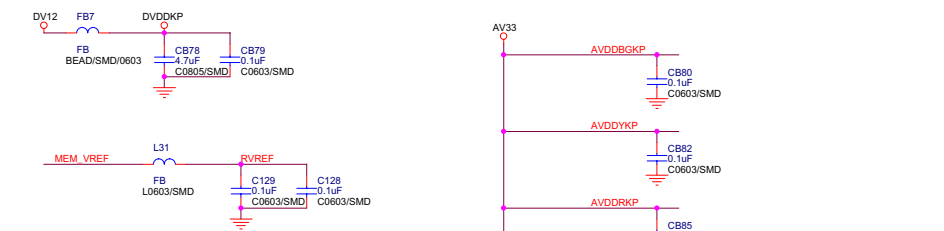
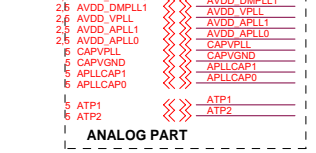
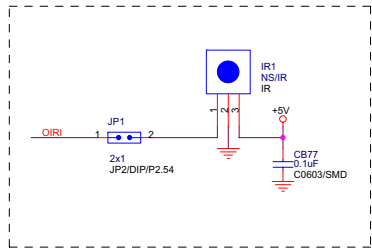
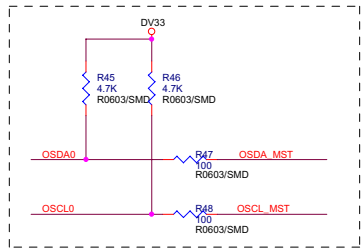
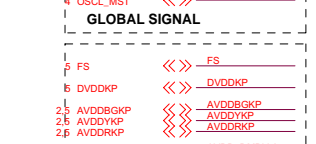
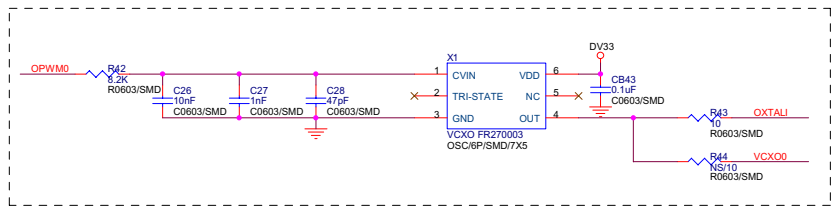
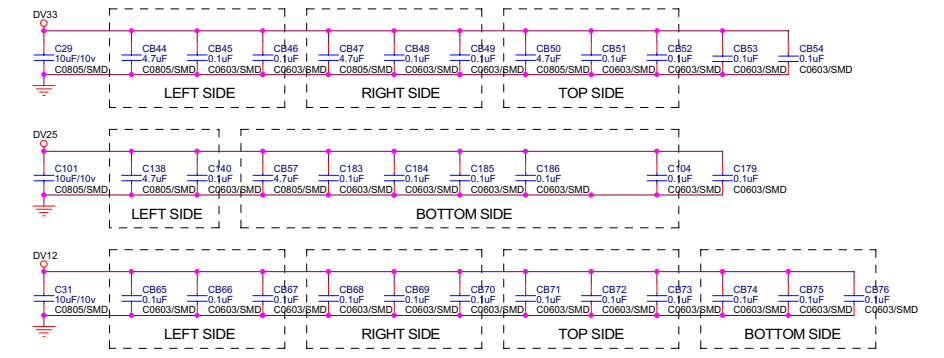
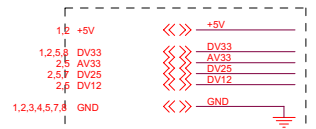
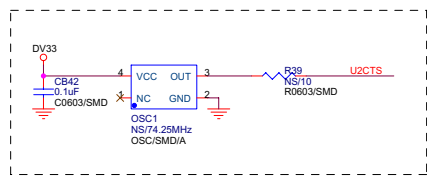
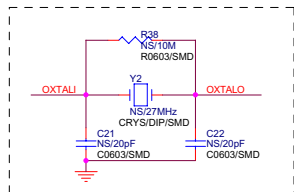
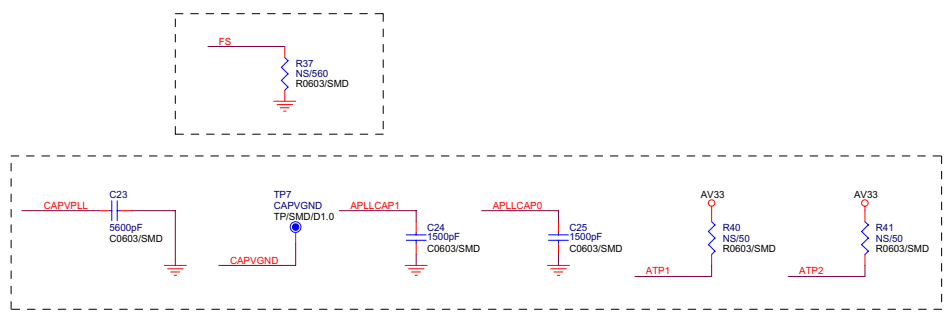

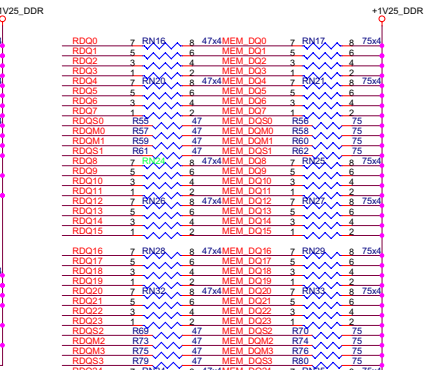
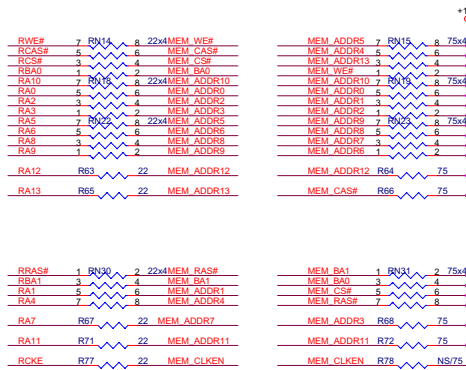

CLOSED TO MT5351

CLOSED TO DDR

CLOSED TO MT5351

CLOSED TO DDR

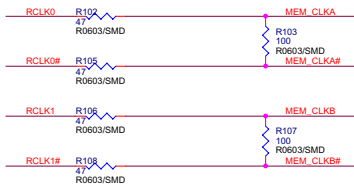

CLOSED TO MT5351

CLOSED TO DDR

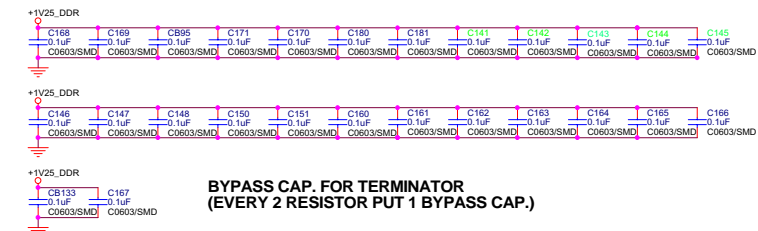

BYPASS CAP. FOR TERMINATOR
(EVERY 2 RESISTOR PUT 1 BYPASS CAP.)

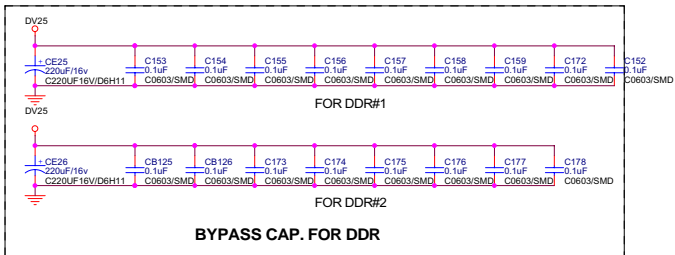

BYPASS CAP. FOR DDR

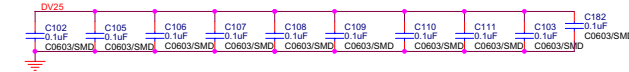

BYPASS CAP. FOR +1V25_DDR

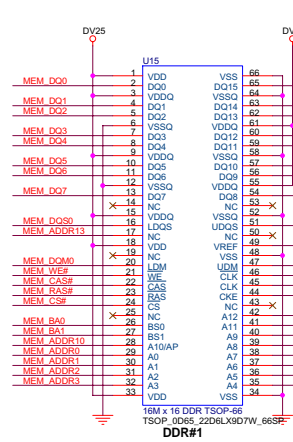

DDR#1

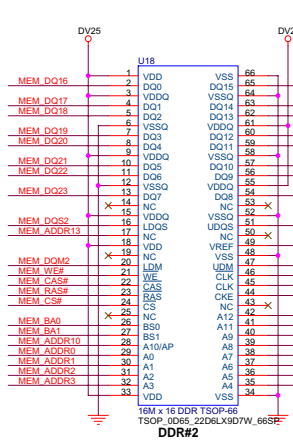

DDR#2



GLOBAL SIGNAL

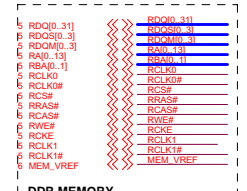

DDR MEMORY EQUAL LINE LENGTH

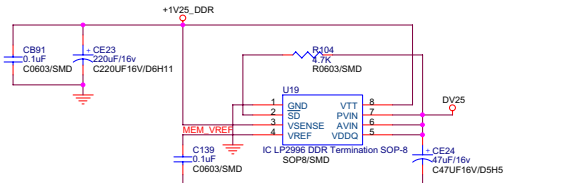

BYPASS CAP. FOR DIMM
+1V25_DDR FOR DDR TERMINATOR
MEM_VREF FOR DDR AND MT5351 VREF

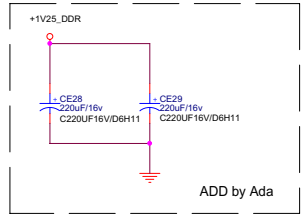

ADD by Ada

MediaTek Confidential

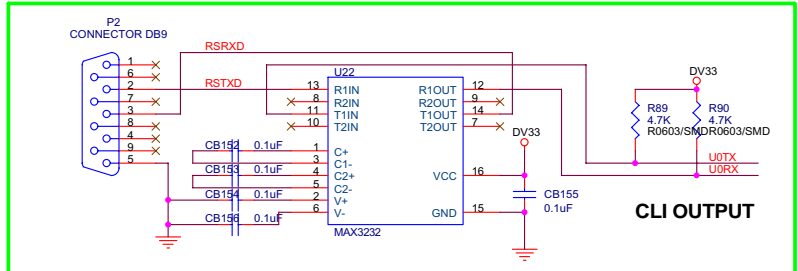
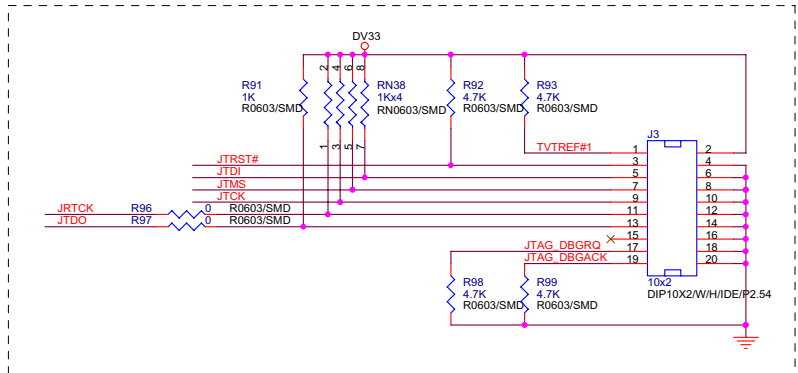
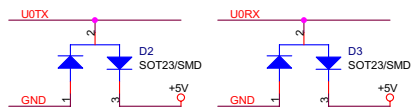
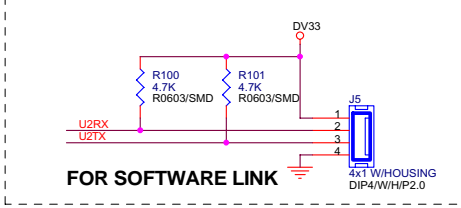
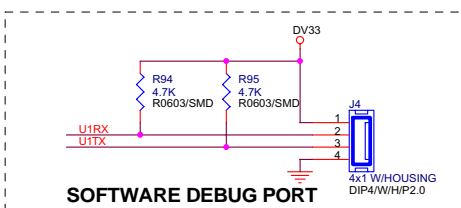
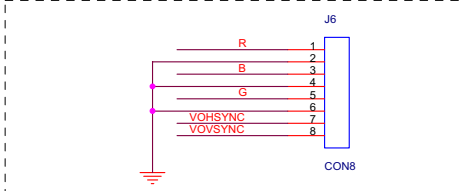
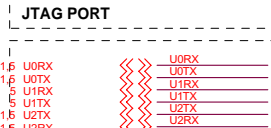
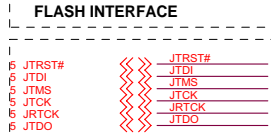
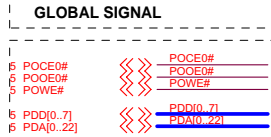
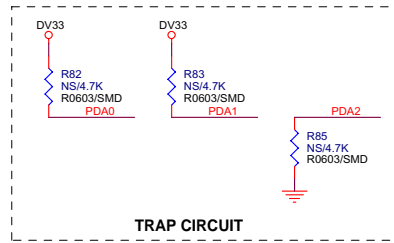
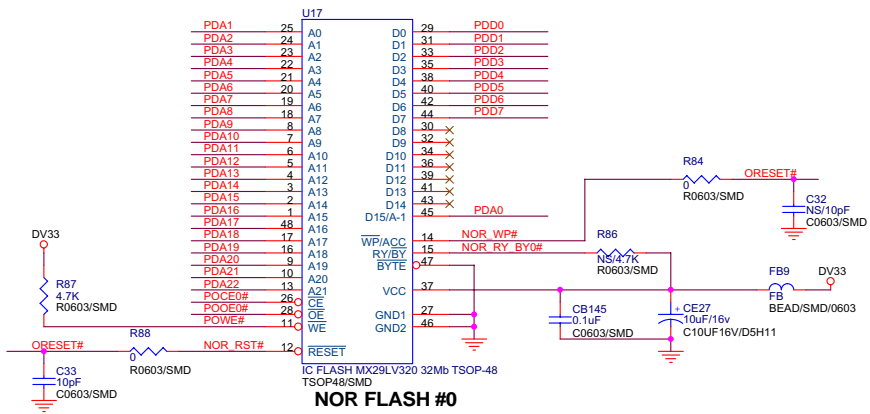

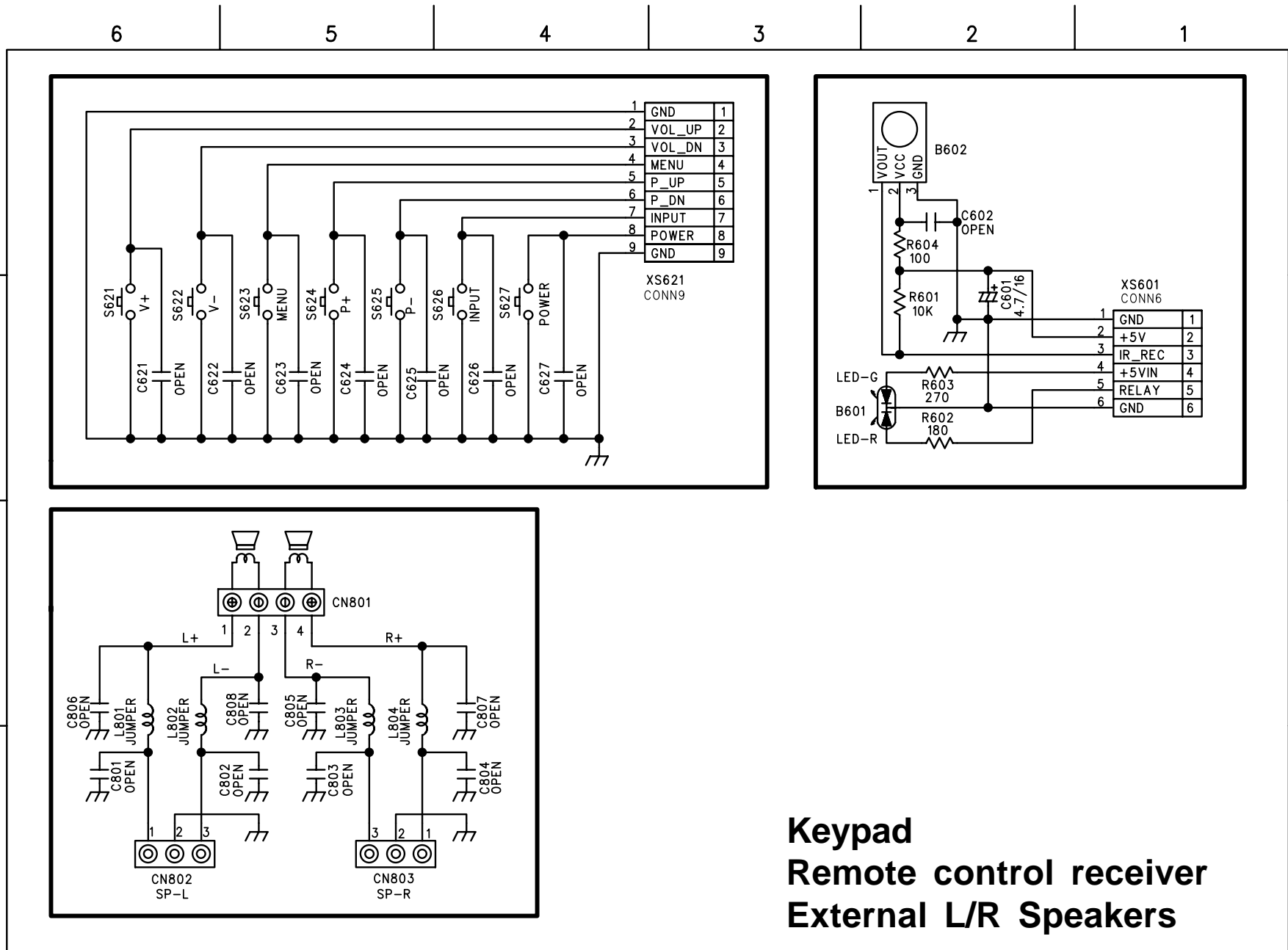

| | | |
|---|--------|---|
| 1 | GND | 1 |
| 2 | VOL_UP | 2 |
| 3 | VOL_DN | 3 |
| 4 | MENU | 4 |
| 5 | P_UP | 5 |
| 6 | P_DN | 6 |
| 7 | INPUT | 7 |
| 8 | POWER | 8 |
| 9 | GND | 9 |

XS621
CONN9

| | | |
|---|--------|---|
| 1 | GND | 1 |
| 2 | +5V | 2 |
| 3 | IR_REC | 3 |
| 4 | +5VIN | 4 |
| 5 | RELAY | 5 |
| 6 | GND | 6 |

XS601
CONN6

Keypad
Remote control receiver
External L/R Speakers

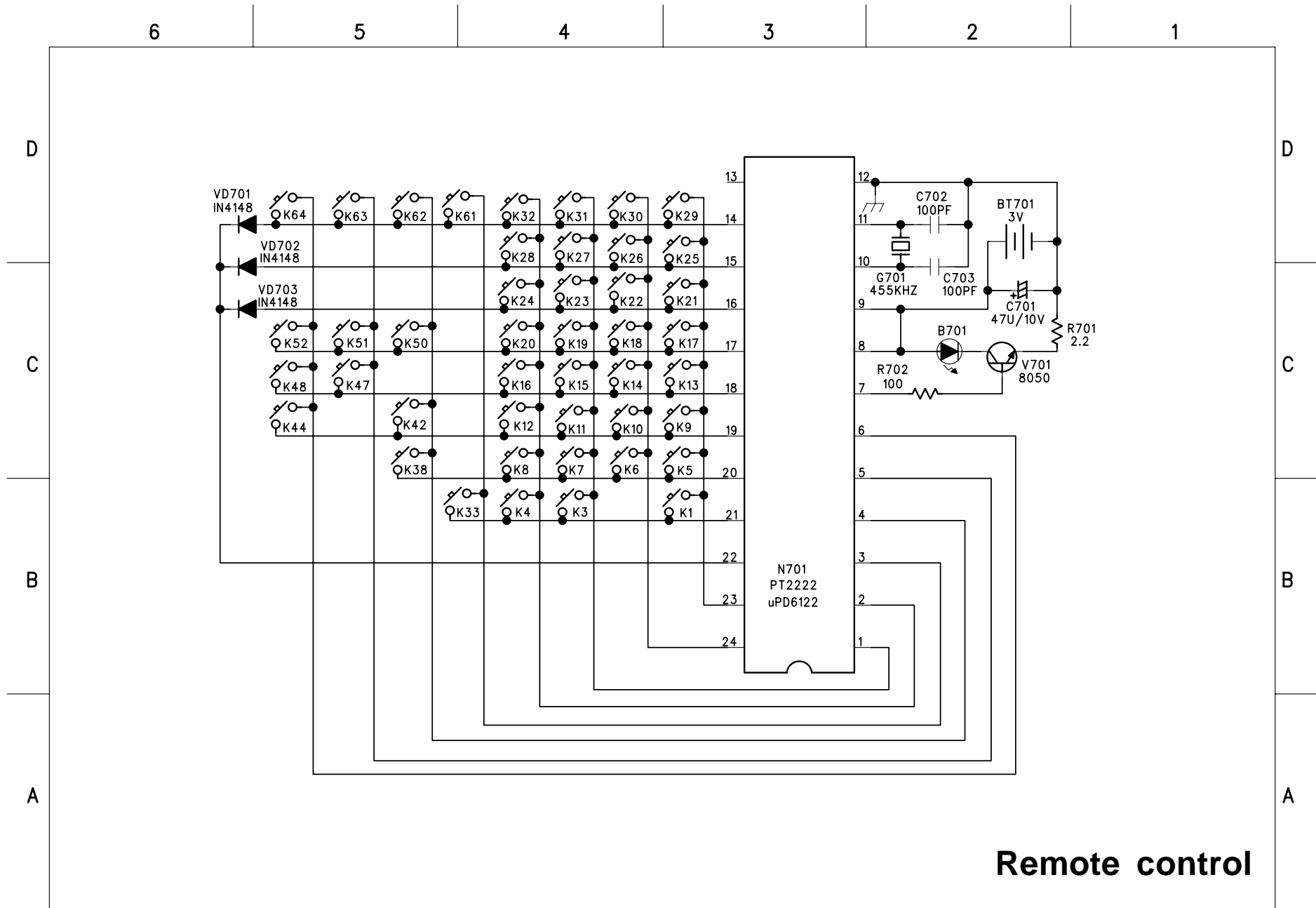

Remote control

Basic Operations & Circuit Description

MODULE

There are 1 pcs panel and 8 pcs PCB including 2 pcs Y/Z Sustainer board, 2 pcs Y Drive board, 2 pcs X (left and right) Extension PCB, 1 pcs Control (Signal Input) and 1 pcs Power board in the Module.

SET

There are 6 pcs PCBs including 1 pcs ATV Tuner board, 1 pcs Keypad board, 1 pcs Remote Control Receiver board, 2 pcs L/R Speakers and 1 pcs Main (Video) board, 1 pcs ATSC board in the SET.

Parts position

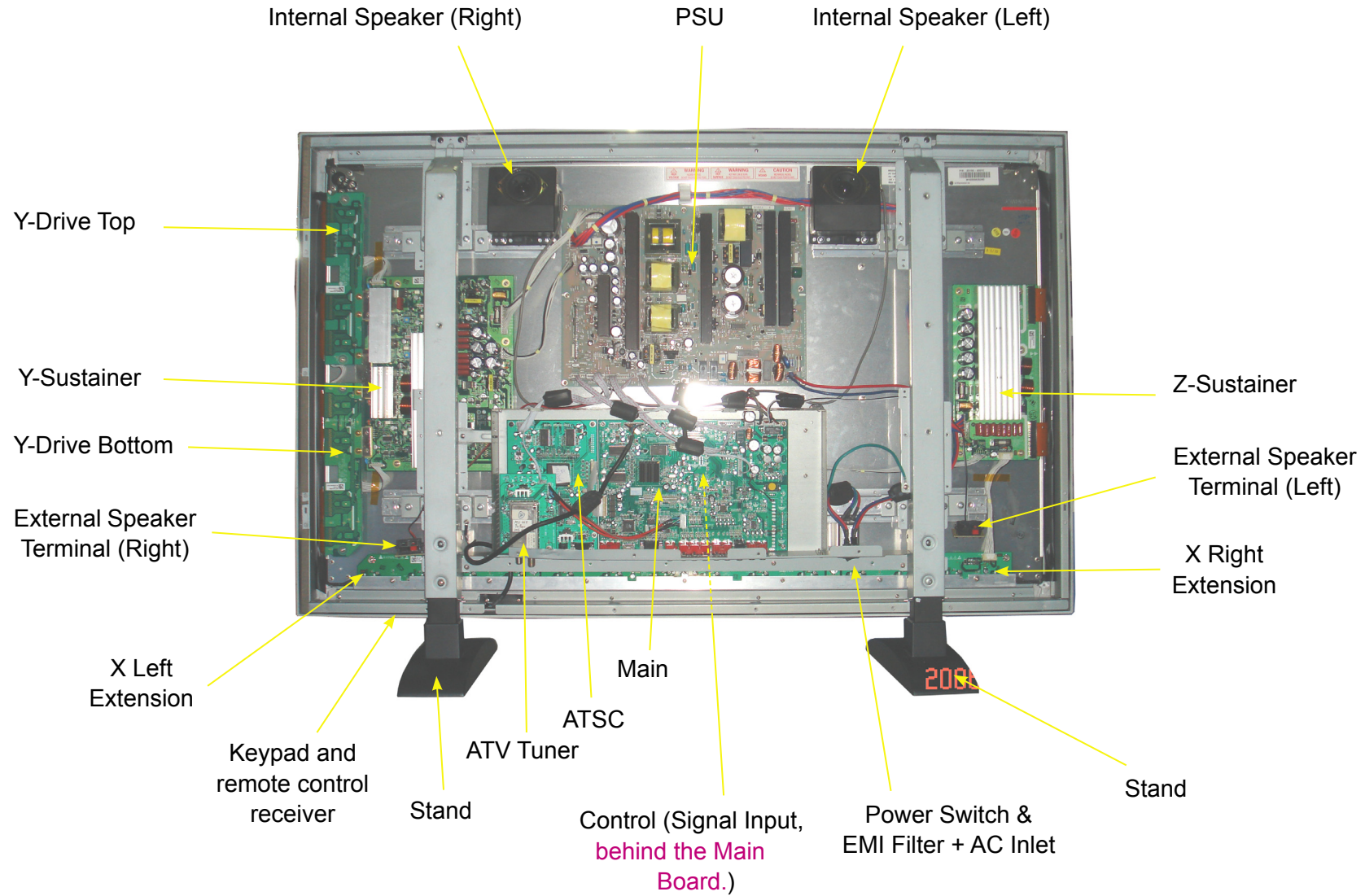

PCB function

- 1. Power:**
 - (1). Input voltage: AC 120V, 60Hz.**
 - (2). To provide power for PCBs.**
- 2. Main board: To converter TV signals, S signals, AV signals, Y Pb/Cb Pr/Cr signals, DVI signals and D-SUB signals to digital ones and to transmit to Control board.**
- 3. Control board: Dealing with the digital signal for output to panel.**
- 4. Y-Sustainer / Z-Sustainer board:**
 - (1). Receiving the signals from Control and high voltage supply.**
 - (2). Output scanning waveform for Module.**
- 5. Y-Drive board: Receive signal from Y sustainer, output horizontal scanning waveform to the panel.**
- 6. X (left and right) extension board: Output addressing signals.**
- 7. ATV Tuner Board: To convert TV RF signal to video and SIF audio signal to Main board.**
- 8. ATSC Board: Receiver and converter ATSC TV signal to transmit to main board.**

PCB failure analysis

- 1. CONTROL: a. Abnormal noise on screen. b. No picture.**
- 2. MAIN :**
 - a. Lacking color, Bad color scale.**
 - b. No voice. (Make sure status: Mute / Internal, External speaker)**
 - c. No picture but with signals output, OSD and back light.**
 - d. Abnormal noise on screen.**
- 3. POWER: No picture, no power output.**
- 4. Z - Sustainer:**
 - a. No picture.**
 - b. Color not enough.**
 - c. Flash on screen.**
- 5. Y - Sustainer: Darker picture with signals.**

- 6. ATV Tuner :**
 - a. No ATV Noise**
 - b. No ATV signals**
- 7. Y/Z - Sustainer: The component working temperature is about 55°C.**
If the temperature rises abnormal, this may be a error point.

- 8. ATSC: a. No ATSC TV signal**

Basic operation of Plasma Display

- 1. After turning on power switch, power board sends 5Vst-by Volt to Main IC MT8202 waiting for ON signals from Key Switch or Remote Receiver.**
- 2. When the ON signal from Key Switch or Remote Receiver is detected, MT8202 will send ON Control signals to Power. Then Power sends (5Vsc, 9Vsc, 12Vsc, 24V and RLY ON, Vs ON) to PCBs working. This time CONTROL Board will send signals to display back light, OSD on the panel and start to search available signal sources. If the audio signals input, they will be amplified by Audio AMP and transmitted to Speakers.**
- 3. If some abnormal signals are detected (for example: over volts, over current, over temperature and under volts), the system will be shut down by Power off.**

Main IC Specifications

- M13S128168A (ESMT)
2M x 16 Bit x 4 Banks Double Data Rate SDRAM
- MT5111CE
Single-Chip HDTV/CATV Demodulator
- MT5351
MT5351 is a DTV Backend Decoder SOC which support flexible transport demux, HD MPEG-2 video decoder, MPEG1,2, MP3, AC3 audio decoder, HDTV encoder. MT5351 is powered by ARM 926EJ with 16K I-Cache and 16K D-Cache. It can support 64Mb to 1Gb DDR DRAM devices with configurable 32/64 bit data bus interface.
- MT8202
MT8202G is a highly integrated Single-Chip for LCD TV supporting video input and output format up to HDTV. It includes 3D comb filter TV decoder to retrieve the best image from popular composite signals.
- MT8293
HDMI PanelLink Cinema Receiver
- R2S15102NP
Digital Power Amplifier R2S15102NP
- WM8776
24-bit, 192kHz Stereo CODEC with 5 Channel I/P Multiplexer

0. Warnings and Cautions

- ✓ WARNING indicates hazards that may lead to death or injury if ignored.
- ✓ CAUTION indicates hazards that may lead to injury or damage to property if ignored.



- 1) This product uses a high voltage (450 V max.). Do not touch the circuitry of this product with your hands when power is supplied to the product or immediately after turning off the power. Be sure to confirm that the voltage is dropped to a sufficiently low level.
- 2) Do not supply a voltage higher than that specified to this product. This may damage the product and may cause a fire.
- 3) Do not use this product in locations where the humidity is extremely high, where it may be splashed with water, or where flammable materials surround it. Do not install or use the product in a location that does not satisfy the specified environmental conditions. This may damage the product and may cause a fire.
- 4) If a foreign substance (such as water, metal, or liquid) gets inside the product, immediately turn off the power. Continuing to use the products it may cause fire or electric shock.
- 5) If the product emits smoke, an abnormal smell, or makes an abnormal sound, immediately turn off the power. If no ting is displayed or if the display goes out during use, immediately turn off the power. Continuing to use the product as it is may cause fire or electric shock.
- 6) Do not disconnect or connect the connector while power to the product is on. It takes some time for the voltage to drop to a sufficiently low level after the power has been turned off. Confirm that the voltage has dropped to a safe level before disconnecting or connecting the connector. Otherwise, this may cause fire, electric shock, or malfunction.
- 7) Do not pull out or insert the power cable from/to an outlet with wet hands. It may cause electric shock.
- 8) Do not damage or modify the power cable. It may cause fire or electric shock.
- 9) If the power cable is damaged, or if the connector is loose, do not use the product; otherwise, this can lead to fire or electric shock.
- 10) If the power connector or the connector of the power cable becomes dirty or dusty, wipe it with a dry cloth. Otherwise, this can lead to fire.

Product Specification of PDP Module



General

- 1) Do not place this product in a location that is subject to heavy vibration, or on an unstable surface such as an inclined surface. The product may fall off or fall over, causing injuries.
- 2) When moving the product, be sure to turn off the power and disconnect all the cables. While moving the product, watch your step. The product may be dropped or fall, leading to injuries of electric shock.
- 3) Do not place this product in a location that is subject to heavy vibration, or on an unstable surface such as an inclined surface. The product may fall off or fall over, causing injuries.
- 4) Before disconnecting cable from the product, be sure to turn off the power. Be sure to hold the connector when disconnecting cables. Pulling a cable with excessive force may cause the core of the cable to be exposed or break the cable, and this can lead to fire or electric shock.
- 5) This product should be moved by two or more persons. If one person attempts to carry this product alone, he/she may be injured.
- 6) This product contains glass. The glass may break, causing injuries, if shock, vibration, heat, or distortion is applied to the product.
- 7) The temperature of the glass surface of the display may rise to 80°C or more depending on the conditions of use. If you touch the glass inadvertently, you may be burned.
- 8) Do not poke or strike the glass surface of the display with a hard object. The glass may break or be scratched. If the glass breaks, you may be injured.
- 9) If you glass surface of the display breaks or is scratched, do not touch the broken pieces or the scratches with bare hands. You may be injured.
- 10) Do not place an object on the glass surface of the display. The glass may break or be scratched.

Design

- 1) This product may be damaged if it is subject to excessive stresses (such as excessive voltage, current, or temperature). The absolute maximum ratings specify the limits of these stresses, and system design must ensure that none of the absolute maximum ratings are exceeded.
- 2) The recommended operating conditions are conditions in which the normal operation of this product is guaranteed. All the rated values of the electrical specifications are guaranteed within these conditions. Always use the product within the range of the recommended operating conditions. Otherwise, the reliability of the product may be degraded. Use of the product with a combination of parameters, conditions, or logic not specified in the specifications of this product is not guaranteed. If intending to use the product in such a way, be sure to consult LGE in advance.
- 3) This product emits near infrared rays (800 to 1000nm) that may cause the remote controllers of other electric products to malfunction. To avoid this, use an infrared absorption filter and thoroughly evaluate the system and environment.

Product Specification of PDP Module

□ Design (continued)

- 4) This product uses high-voltage switching and a high –speed clock. A system using this product should be designed so that it does not affect the other systems, and should be thoroughly evaluated.
- 5) This product has a glass display surface. Design your system so that excessive shock and load are not applied to the glass. Exercise care that the vent at the corner of the glass panel is not damaged. If the glass panel or vent is damaged, the product is inoperable.
- 6) There are some exposed components on the rear panel of this product. Touching these components may cause an electric shock.
- 7) This product uses a high voltage. Design your system so that any residual voltage in this product is dissipated quickly when power is turned off, observing the specifications.
- 8) This product uses heat-emitting components. Take the heat emitted by these components into consideration when designing your system. If the product is used outside the specified temperature range, it may malfunction.
- 9) This product uses a high voltage and, because of its compact design, components are densely mounted on the circuit board. If dust collects on these components, it can cause short-circuiting between the pins of the components and moisture can cause the insulation between the components to break down, causing the product to malfunction.
- 10) Regulations and standards on safety and electromagnetic interference differ depending on the country. Design your system in compliance with the regulations and standards of the country for which your system is intended.
- 11) To obtain approval under certain safety standards (such as UL and EN), a filter that passes a shock test must be fitted over the glass surface of the finished product. In addition, it must be confirmed that the level of UV emissions is within the range specified by such standards.
- 12) If this product is used as a display board to display a static image, “image sticking” occurs. This means that the luminance of areas of the display that remain lit for a long time drops compared with the luminance of areas that are lit for a shorter time, causing uneven luminance across the display. The degree to which this occurs is in proportion to the luminance at which the display is used. To prevent this phenomenon, therefore, avoid static images as much as possible and design your system so that it is used at a low luminance, by reducing signal level difference between bright area and less bright area through signal processing.
- 13) Within the warranty period, general faults that occur due to defects in components such as ICs will be rectified by LGE without charge. However, IMAGE STICKING is not included in the warranty. Repairs due to the other faults may be charged for depending on responsibility for the faults.
- 14) In case of AC PDP driving mechanism, Because the brightness of output is not always proportional to input signals. Therefore the non-linearity of gray can occasionally be observed in certain gray levels as well as Contour and Error Diffusion Noise can be appeared when a dark picture is on the screen especially. These are phenomena that can be observed on the PDP driving mechanism. With simple adjustment to picture brightness control, these can be reduced considerably.
- 15) Because of the need to control the power consumption on the PDP driving mechanism, the APL(Average Picture Level) mode was equipped. Thus, as the picture on the screen changes, there can be slightly switched in brightness. This also is a phenomenon that can be observed on the PDP driving mechanism.
- 16) This product is designed to LGE’s “Standard” quality grade. If you wish to use the product for applications outside the scope of the “Standard” quality grade, be sure to consult LGE in advance to assess the technological feasibility before starting to design your system.

Product Specification of PDP Module

USE

- 1) Because this product uses a high voltage, connecting or disconnecting the connectors while power is supplied to the product may cause malfunctioning. Never connect or disconnect the connectors while the power is on. Immediately after power has been turned off, a residual voltage remains in the product. Be sure to confirm that the voltage has dropped to a sufficiently low level.
- 2) Watching the display for a long time can tire the eyes. Take a break at appropriate intervals.
- 3) PDP's brightness and contrast ratio is lower than that of the CRT. The picture is dimmer with surrounding light and better for viewing in dark condition.
- 4) Do not cover or wrap the product with a cloth or other covering while power is supplied to the product.
- 5) Before turning on power to the product, check the wiring of the product and confirm that the supply voltage is within the rated voltage range. If the wiring is wrong or if a voltage outside the rated range is applied, the product may malfunction or be damaged.
- 6) Do not store this product in a location where temperature and humidity are high. This may cause the product to malfunction. Because this product uses a discharge phenomenon, it may take time to light (operation may be delayed) when the product is used after it has been stored for a long time. In this case, it is recommended to light all cells for about 2hours (aging).
- 7) If the glass surface of the display becomes dirty, wipe it with a soft cloth moistened with a neutral detergent. Do not use acidic or alkaline liquids, or organic solvents.
- 8) Do not tilt or turn upside down while the module package is carried, the product may be damaged.
- 9) This product is made from various materials such as glass, metal, and plastic. When discarding it, be sure to contact a professional waste disposal operator.

Repair and Maintenance

Because this product combines the display panel and driver circuits in a single module, it cannot be repaired or maintained at user's office or plant. Arrangements for maintenance and repair will be determined later

Others

- 1) If your system requires the user to observe any particular precautions, in addition to the above warnings and cautions, include such caution and warning statements in the manual for your system.
- 2) If you have any questions concerning design, such as on housing, storage, or operating environment, consult LGE in advance.

1. GENERAL DESCRIPTION

□ DESCRIPTION

The PDP42V7##### is a 42-inch 16:9 color plasma display module with resolution of 852(H) × 480(V) pixels. This is the display device which offers vivid colors with adopting AC plasma technology by LG Electronics Inc.

□ FEATURES

High peak brightness (1500cd/m² Typical) and high contrast ratio (10,000:1 Typical) enables user to create high performance PDP SETs.

□ APPLICATIONS

- ✓ General television systems
- ✓ Public information display
- ✓ Video conference systems
- ✓ Education and training systems



Product Specification of PDP Module

□ ELECTRICAL INTERFACE OF PLASMA DISPLAY

The PDP42V7#### requires only 8/10bits of digital video signals for each RGB color.
In addition to the video signals, six different DC voltages are required to operate the display.

□ GENERAL SPECIFICATIONS

- ✓ Model Name : PDP42V7#### (42V7#### Model)
- ✓ Number of Pixels : 852(H) × 480(V) (1pixel=3 RGB cells)
- ✓ Pixel Pitch : 1080μm (H) × 1080μm (V)
- ✓ Cell Pitch : 320μm (H) × 1080μm (V) (Green Cell basis)
- ✓ Display Area : 920.1(H) × 518.4(V) ±0.5mm
- ✓ Outline Dimension : 1005(H) × 597(V) × 60.7(D) ± 1mm
- ✓ Pixel Type : RGB Closed type (well)
- ✓ Number of Gradations : (R)1024 × (G)1024 × (B)1024
- ✓ Weight : 14.7 Kg ± 0.5 Kg (Net 1EA)
100 Kg ± 5 Kg (5EA/1BOX)
- ✓ Aspect Ratio : 16:9
- ✓ Peak Brightness : Typical 1500cd/m² (1/100 White Window)
- ✓ Contrast Ratio : Average 100:1 (In a bright room with 100Lux at center)
: Typical 10,000:1 (In a dark room 1/100 White Window pattern at center)
- ✓ Power Consumption : Typical 200 W (Full White)^{*note1)}
- ✓ Expected Life-time : more than 60,000 Hours of continuous operation

Life-time is defined as the time when the brightness becomes half of its initial value.

✓ Display Dot Diagram

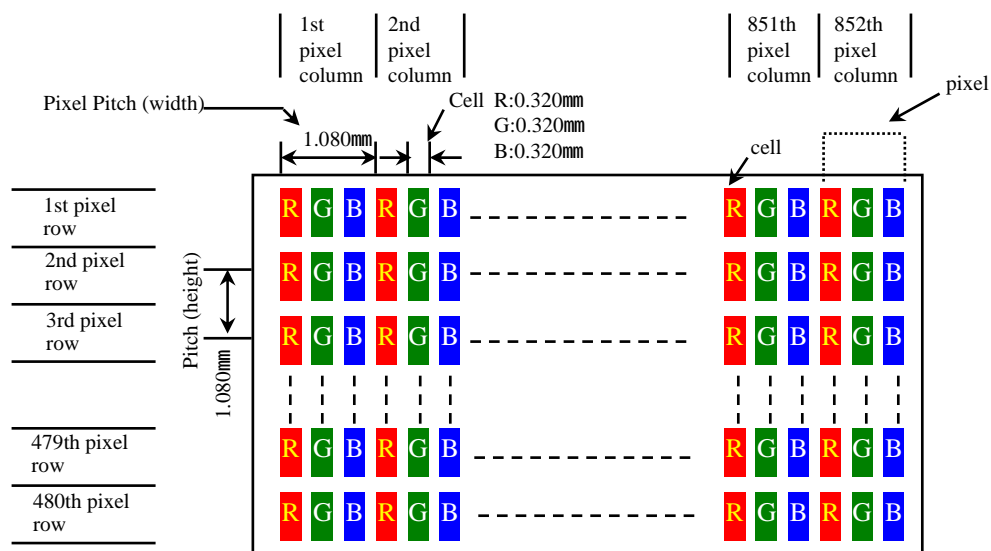

* Note 1) Total Power Consumption can be up to 300W according to the displayed pattern.

Product Specification of PDP Module

□ BLOCK DIAGRAM

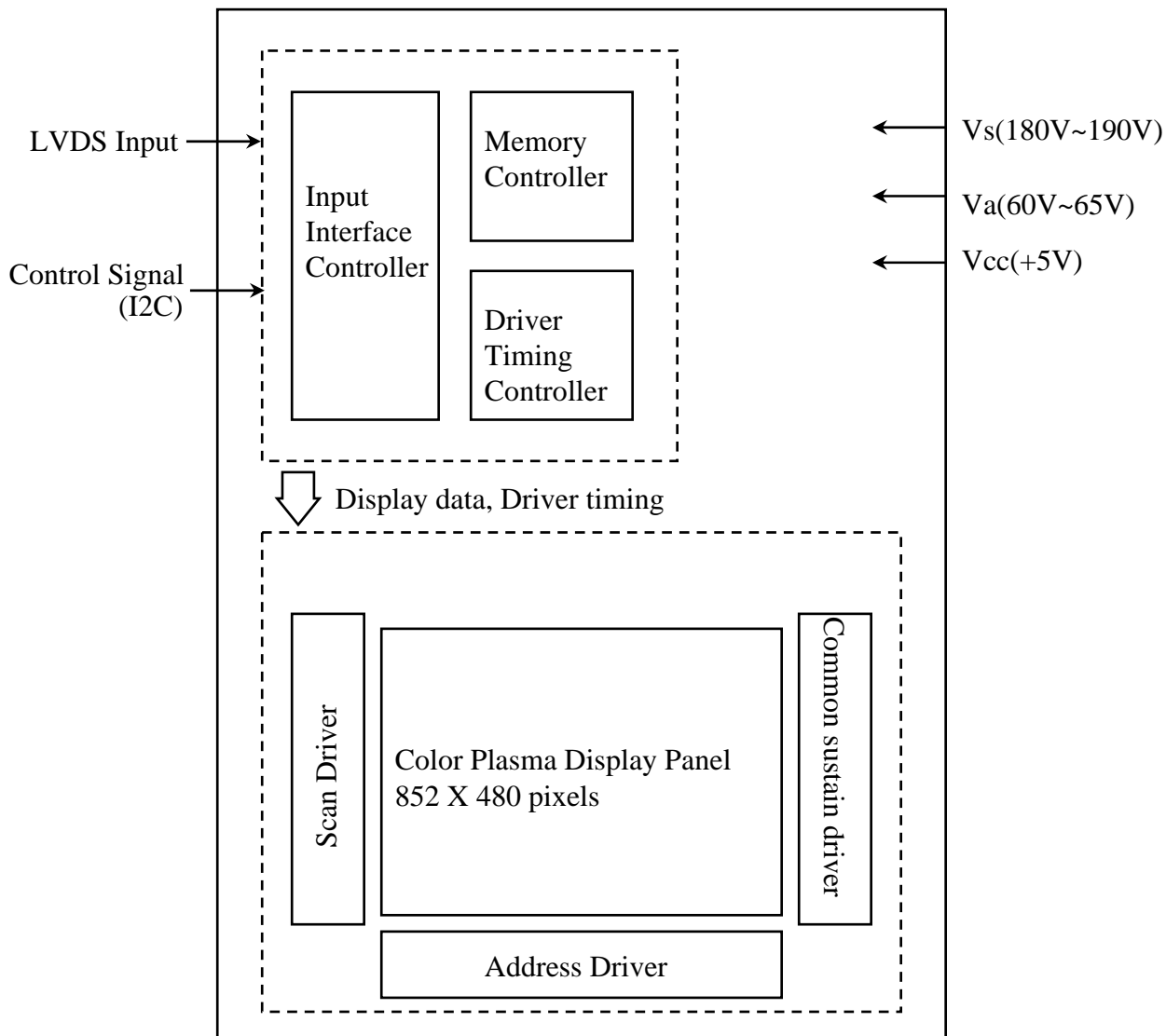

Applied Voltage level is specified at the time when Full-White pattern is displayed on the panel.

Product Specification of PDP Module

□ LVDS Signal and LVDS Receiver

(P1001) : LG Cable, GT121-31P-TD

| Pin No. | Symbol | Pin No. | Symbol | Pin No. | Symbol |
|---------|--------|---------|--------|---------|----------------------|
| 1 | GND | 11 | RD- | 21 | nc |
| 2 | RA- | 12 | RD+ | 22 | nc |
| 3 | RA+ | 13 | GND | 23 | nc |
| 4 | RB- | 14 | GND | 24 | RE- |
| 5 | RB+ | 15 | nc | 25 | RE+ |
| 6 | GND | 16 | nc | 26 | GND |
| 7 | RC- | 17 | nc | 27 | DISPEN |
| 8 | RC+ | 18 | nc | 28 | I ² C SDA |
| 9 | RCLK- | 19 | GND | 29 | I ² C SCL |
| 10 | RCLK+ | 20 | nc | 30 | nc |
| | | | | 31 | GND |

} 3.3V level

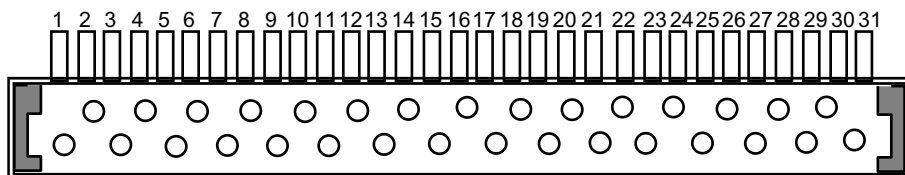

LG Cable, GT121-31P-TD pin number (Top view)

➤ Definitions and Functions of LVDS Signal

| Symbol | Definition and Function | Related Output Signal |
|--------|-------------------------------|-------------------------------------|
| RA + | Channel-A Pos. Receiver Input | R4, R5, R6, R7, R8, R9, G4 |
| RA - | Channel-A Neg. Receiver Input | |
| RB + | Channel-B Pos. Receiver Input | G5, G6, G7, G8, G9, B4, B5 |
| RB - | Channel-B Neg. Receiver Input | |
| RC + | Channel-C Pos. Receiver Input | B6, B7, B8, B9, Hsync, Vsync, BLANK |
| RC - | Channel-C Neg. Receiver Input | |
| RD + | Channel-D Pos. Receiver Input | R2, R3, G2, G3, B2, B3, nc |
| RD - | Channel-D Neg. Receiver Input | |
| RE + | Channel-E Pos. Receiver Input | R0, R1, G0, G1, B0, B1, nc |
| RE - | Channel-E Neg. Receiver Input | |
| RCLK + | Clock Pos. Receiver Input | PIX_CLK |
| RCLK - | Clock Neg. Receiver Input | |

7. CONNECTORS and CONNECTIONS

❑ Power Input Connector

➤ Connector P3001 Pin Assignment

| Pin No. | Symbol | Pin No. | Symbol |
|---------|--------|---------|--------|
| 1 | Vs | 5 | GND |
| 2 | Vs | 6 | Va |
| 3 | nc | 7 | GND |
| 4 | GND | 8 | +5V |

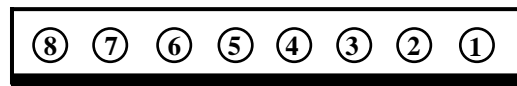

1-1123723-8 Pin numbers
(Top View, viewed from the pin connection side)

- ✓ Module side connector : 1-1123723-8 (Header)
- ✓ Mating Connector : 1-1123722-8 (Housing)
- ✓ Connector Supplier : AMP

➤ Connector P2005 Pin Assignment

| Pin No. | Symbol | Pin No. | Symbol |
|---------|--------|---------|--------|
| 1 | VS | 6 | GND |
| 2 | VS | 7 | GND |
| 3 | VS | 8 | GND |
| 4 | nc | 9 | nc |
| 5 | GND | 10 | nc |

- ✓ Module side connector : 1-1123723-10 (Header)
- ✓ Mating Connector : 1-1123722-10 (Housing)
- ✓ Connector Supplier : AMP

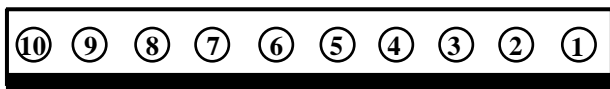

1-1123723-10 Pin numbers
(Top View, viewed from the pin connection side)

➤ Connector P2006 Pin Assignment

| Pin No. | Symbol | Pin No. | Symbol |
|---------|--------|---------|--------|
| 1 | GND | 3 | 5V |
| 2 | GND | 4 | 5V |

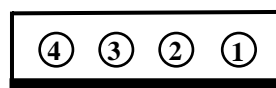

1-1123723-4 Pin numbers
(Top View, viewed from the pin connection side)

- ✓ Module side connector : 1-1123723-4 (Header)
- ✓ Mating Connector : 1-1123722-4 (Housing)
- ✓ Connector Supplier : AMP

Product Specification of Power Supply Unit

3. Output Specification

3.1 Output Voltage & Load Condition

| | Output Name | Output Typical (V) | Variable Voltage Range(V) | Voltage Tolerance (%) | Output Current(A) | | *2Ripple & Noise (Vp-p) |
|------------------------------|---------------------|--------------------|---------------------------|-----------------------|-------------------|------|-------------------------|
| | | | | | Min. | Max. | |
| Vsc Board (Signal Interface) | 5V Stand_by | 5.0 | - | ±5 | 0.03 | 1.0 | 100mVp-p |
| | 5Vsc | 5.0 | - | ±5 | 0.5 | 4.5 | 200mVp-p |
| | 9Vsc | 9 | - | ±5 | 0 | 2.0 | 100mVp-p |
| | 12Vsc | 12 | - | ±5 | 0 | 1.0 | 200mVp-p |
| | Vaudio (selectable) | 24 | - | ±12 | 0 | 1.25 | 500mVp-p |
| | | 30 | - | ±12 | 0 | 1.0 | 500mVp-p |
| *1PDP Module | 5Vctrl | 5.0 | - | ±5 | 0.5 | 4.5 | 200mVp-p |
| | Va | 60 | ±5 | ±1 | 0.005 | 1.4 | 600mVp-p |
| | Vs | 190 | -10, +5 | ±1 | 0.1 | 1.3 | 600mVp-p |

*1. PDP Module Maximum Power are below **300W at all gray scale of full white.**

*2. Ripple & Noise measurement method

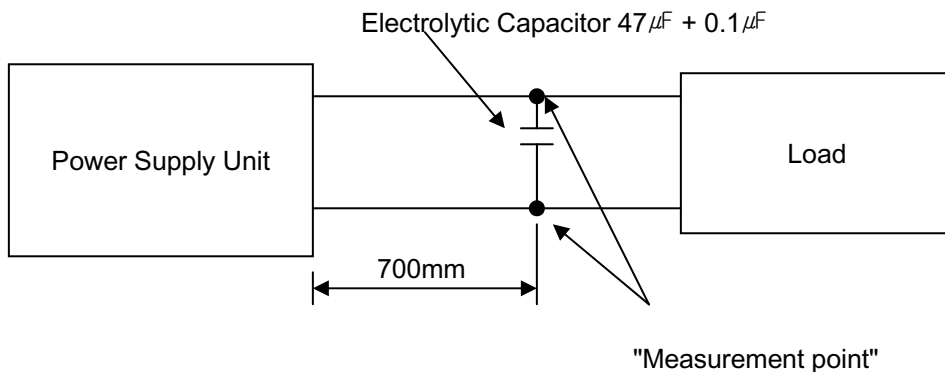

Product Specification of Power Supply Unit

7. Input/Output pin assignment & specification

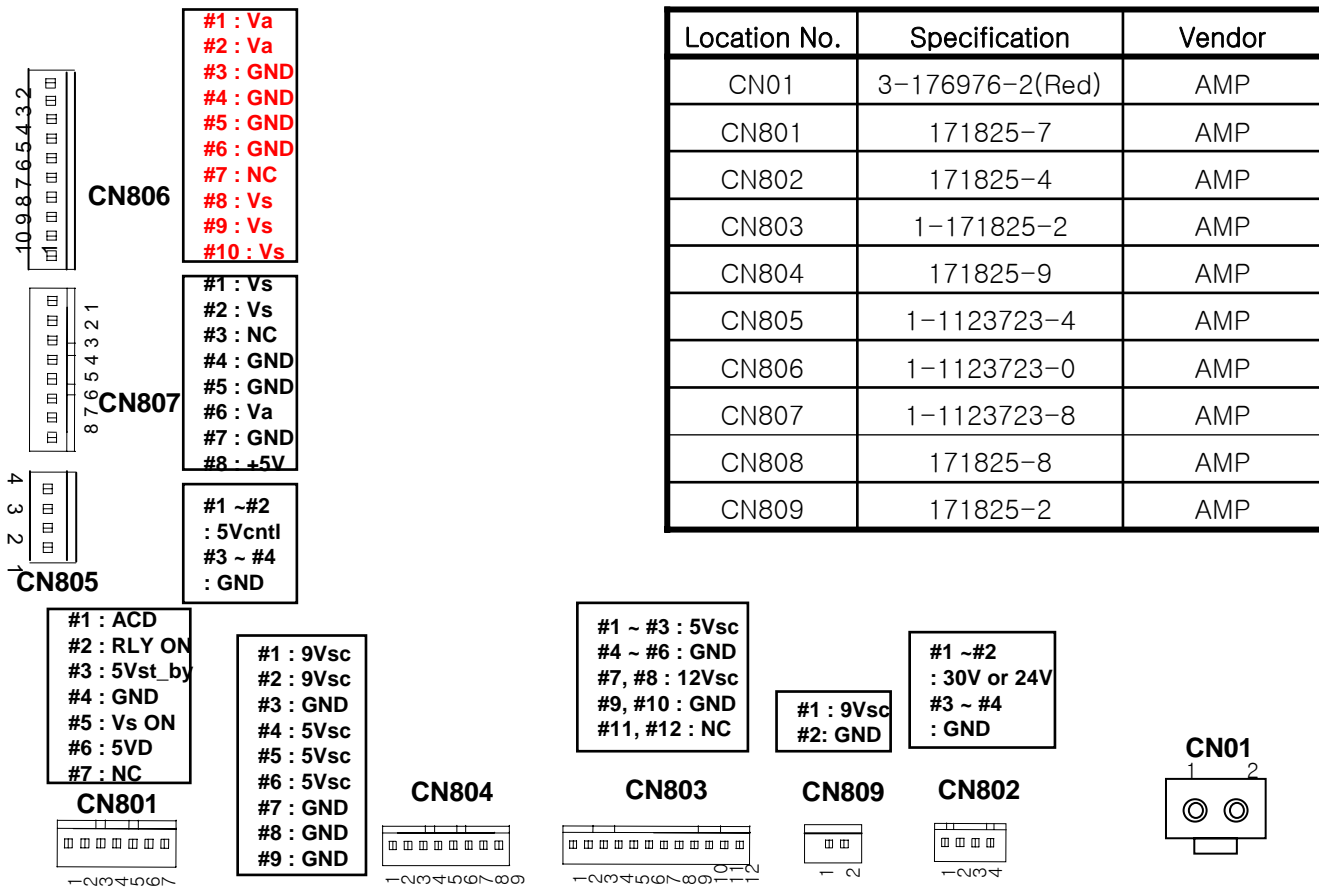

| Location No. | Specification | Vendor |
|--------------|-----------------|--------|
| CN01 | 3-176976-2(Red) | AMP |
| CN801 | 171825-7 | AMP |
| CN802 | 171825-4 | AMP |
| CN803 | 1-171825-2 | AMP |
| CN804 | 171825-9 | AMP |
| CN805 | 1-1123723-4 | AMP |
| CN806 | 1-1123723-0 | AMP |
| CN807 | 1-1123723-8 | AMP |
| CN808 | 171825-8 | AMP |
| CN809 | 171825-2 | AMP |

8. Adjustment detail

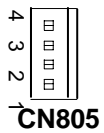
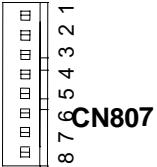
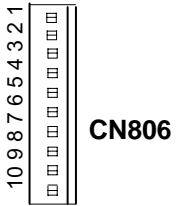

* You can select output Audio Voltage(24V or 30V)
Shipment condition : 24V

Selection Pin

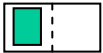

Normal (Mode1) Auto (Mode2)

Selection Wire

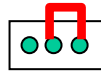

30V 24V



CN804



CN803

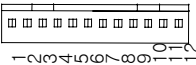

CN809



CN802

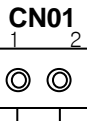

* PSU driving method Switch

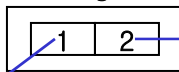

Auto(Mode2) : Driving without interface Board

Normal(Mode1) : Driving with interface Board

Spare Part List for PDP4210EA1

| Item | Part Number | Part Description | Usage / unit | Unit | Key/Spare |
|------|--------------------|--------------------------------------------------------------|--------------|-------|-----------|
| | PDP42EAAAIA1LS-A01 | ILO PDP42" (PDP4210EA1) USA AC120/60HZ MT8202/LG-V7 BLACK | | | |
| 1> | 510-42AA01-STU01K | CARTON BOX ILO ENG PDP4210EA1 (S-MT8202) LGV7 USA K | 1.000000 | Piece | K |
| 2> | 518-42AA01-01K | BTM TRAY 42AA R | 1.000000 | Piece | K |
| 3> | 580-P42AAES-TU01L | IB E FOR ILO PDP4210EA1 DTV LGV7 S-MTK8202 USA | 1.000000 | Piece | K |
| 4> | E7501-051009 | ILO REMOTE CONTROL K001 44KEYS BLACK | 1.000000 | SET | K |
| 5> | 771E42D103-01 | MAIN PCB ASSY MT8202/LG-V7 | 1.000000 | SET | K |
| 6> | 771L42D103-02 | NTSC TUNER PCB ASSY | 1.000000 | SET | K |
| 7> | 771S42D102-01 | ATSC TUNER PCB ASSY | 1.000000 | SET | K |
| 8> | 200-42AA02-STK01A | FRONT CABINET BLACK ILO ENG 42AA(S-MT8202) A | 1.000000 | Piece | S |
| 9> | 244-34B811-01 | GIFT BOX HANDLE 34B8 | 2.000000 | Piece | S |
| 10> | 248-46D201-01 | HANDLE FOR PLASMA BLACK | 2.000000 | Piece | S |
| 11> | 263-42D101-01S | POWER LENS 42D1 S | 1.000000 | Piece | S |
| 12> | 269-42D101-01L | REMOTE LENS 42D1 L | 1.000000 | Piece | S |
| 13> | 300-42AA01-02C | POLYFOAM FOR BTM L&R 42AA | 1.000000 | Piece | S |
| 14> | 300-42AA02-02C | POLYFOM FOR TOP L&R 42AA | 1.000000 | Piece | S |
| 15> | 310-111404-07V | POLYBAG 11"X14"X0.04 FV | 1.000000 | Piece | S |
| 16> | 310-504004-01 | POLYBAG EPF 50"X40"X0.04 | 1.000000 | Piece | S |
| 17> | 329-056010-50 | SPONGE 560X10X5.0MM W/ ADHESIVE | 2.000000 | Piece | S |
| 18> | 329-098010-50 | SPONGE 980X10X5.0MM W/ ADHESIVE | 2.000000 | Piece | S |

Spare Part List for PDP4210EA1

| | | | | | |
|-----|-------------------|-------------------------------------------------------------|----------|-------|---|
| 19> | 384-42AA01-STU01H | SHEET FOR TERMINAL PDP4210EA1 (S-MT8202) USA H | 1.000000 | Piece | S |
| 20> | 387-42AA01-STU01H | MODEL PLATE ILO ENG DP4210EA1 (S-MT8202) USA H | 1.000000 | Piece | S |
| 21> | 388-42D102-01 | PC SHEET FOR REMOTE PCB42D1 94V0 0.3MM | 1.000000 | Piece | S |
| 22> | 388-42D103-01H | CAUTION PLATE ENG 42D1 H | 1.000000 | Piece | S |
| 23> | 388-50AA01-01H | SPEAKER L PLATE ENG (-/+) | 1.000000 | Piece | S |
| 24> | 388-50AA01-02H | SPEAKER R PLATE ENG (-/+) | 1.000000 | Piece | S |
| 25> | 402-42AA03-01S | BACK COVER FOR LG PANEL W/O POWER WIDOW | 1.000000 | Piece | S |
| 26> | 436-42AA0A-01S | TERMINAL SHEET MT8202 HDMI 42AA | 1.000000 | Piece | S |
| 27> | 481-42AA03-01S | SHIELD BOX MTK8202 42AA | 1.000000 | Piece | S |
| 28> | 483-50AA01-01 | SHIELD BOX COVER 50AA | 1.000000 | Piece | S |
| 29> | 512-42AA03-01 | CARTON SHEET 1380X960X3.0MM | .285600 | Piece | S |
| 30> | 512-42D102-01 | SHEET 1160X1480 42D1 | .285600 | Piece | S |
| 31> | 553-004009-25A | SHIELD GASKET 40X9X2.5MM W/ CONDUCTIVE ADHESIVE | 4.000000 | Piece | S |
| 32> | 553-005009-25A | SHIELD GASKET 50X9X2.5MM W/ CONDUCTIVE ADHESIVE KI JD-60 | 1.000000 | Piece | S |
| 33> | 553-011009-25A | SHILED GASKET 110X9X2.5MM W/ CONDUCTIVE ADHESIVE | 6.000000 | Piece | S |
| 34> | 553-015009-25A | SHIELD GASKET 150X9X2.5MM W/ CONDUCTIVE ADHESIVE | 4.000000 | Piece | S |
| 35> | 553-017009-25A | SHIELD GASKET 170X9X2.5 | 8.000000 | Piece | S |
| 36> | 553-056007-10A | SHIELD GASKET 560X7X1.0MM W/ CONDUCTIVE ADHESIVE | 1.000000 | Piece | S |
| 37> | 553-056009-40A | SHIELD GASKET 560X9X4.0 W/ CONDUCTIVE ADHESIVE | 2.000000 | Piece | S |
| 38> | 553-098009-40A | SHIELD GASKET 980X9X4.0MM W/ CONDUCTIVE ADHESIVE | 2.000000 | Piece | S |

Spare Part List for PDP4210EA1

| | | | | | |
|-----|----------------|---------------------------------------------------------------------|----------|-------|---|
| 39> | 554-080055-01 | SHIELD CLOTH 80X55 W/ CONDUCTIVE ADHESIVE | 1.000000 | Piece | S |
| 40> | 563-119- | SERIAL NO. LABEL | 1.000000 | Piece | S |
| 41> | 568-P46T02-02 | WARNING LB ENG 42SF NIL | 1.000000 | Piece | S |
| 42> | 579-42AA01-08 | BAR CODE LABEL (W/SERIAL NO) ENG PDP4210EA1 USA | 2.000000 | Piece | S |
| 43> | 579-42D102-09 | SERIAL NO/BAR CODE LABEL 42D1 | 1.000000 | Piece | S |
| 44> | 579-42D105-01 | PROTECTIVE EARTH LABEL FOR ESA 42TD1 | 1.000000 | Piece | S |
| 45> | 590-42AA01-06 | WARRANTY CARD ILO ENG PDP4210EA1 USA | 1.000000 | Piece | S |
| 46> | 593-42AA01-04 | ILO INSERTION CARD FOR PDP4210EA1 USA | 1.000000 | Piece | S |
| 47> | 900-420205-01B | DISPLAY FILTER 42" SSC FOR LG (984X584X3.3)(S1-NEW MESH TYPE) | 1.000000 | Piece | S |
| 48> | E3404-157004 | AC CORD UL 1.88M (YY-3/ST3 YUNBIAO) | 1.000000 | Piece | S |
| 49> | E3421-926106 | WIRE ASSY P2.5 4P L=210 EMI | 1.000000 | Piece | S |
| 50> | E3421-926113 | WIRE ASSY 31P L=260 EMI FOR LGV7 | 1.000000 | Piece | S |
| 51> | E3421-926114 | WIRE ASSY P2.5 9P/8P+4P L=300/240 EMI | 1.000000 | Piece | S |
| 52> | E3421-926117 | WIRE ASSY P2.5 5P/3P+3P L=700/450 EMI FOR SPK | 1.000000 | Piece | S |
| 53> | E3421-926118 | WIRE ASSY KEY 2.0MM 13P L=600 EMI | 1.000000 | Piece | S |
| 54> | E3421-926119 | WIRE ASSY P2.0 8P L=215 TV/SIF | 1.000000 | Piece | S |
| 55> | E3421-926120 | WIRE ASSY P2.5 12P+2P/11P+10P L=270/300 EMI | 1.000000 | Piece | S |
| 56> | E3421-926121 | WIRE ASSY P2.5 7P L=210 EMI | 1.000000 | Piece | S |
| 57> | E3421-927001 | WIRE ASSY AMP/AMP-2Y/530 (FROM SWITCH POW) | 1.000000 | Piece | S |
| 58> | E4101-027001 | SWITCH POW MR-22-N2BB-F2 ROCKET | 1.000000 | Piece | S |

Spare Part List for PDP4210EA1

| | | | | | |
|-----|---------------|-----------------------------------------------------|----------|-------|---|
| 59> | E6205-001006 | DISPLAY PDP 42" LG-V7 (WVGA) 107CM | 1.000000 | Piece | S |
| 60> | E7301-010002 | BATTERY AAA R03P1.5V <2> | 2.000000 | Piece | S |
| 61> | 734-BP0301-01 | PLASTIC BASE /DUCK FEET BLACK H185MM | 1.000000 | SET | S |
| 62> | 771-50AA03-01 | KEY PCB ASSY FOR PD50HAA SANSUI PW181 CHASSIS | 1.000000 | SET | S |
| 63> | 771-50AA05-01 | SPK JACK PCB ASSY | 1.000000 | SET | S |
| 64> | 771B42AA02-01 | IR RECEIVE PCB ASSY FOR PDP4210EA1 | 1.000000 | SET | S |
| 65> | 786-SPA106-01 | INT SPK ASSY FOR PDP4210EA1 (LGV7) 16 OHM 7W D2" | 1.000000 | SET | S |

NOTE : THIS RELEASED DRAWING WAS PRODUCED BY COMPUTER , DO NOT UPDATE MASTER MANUALLY

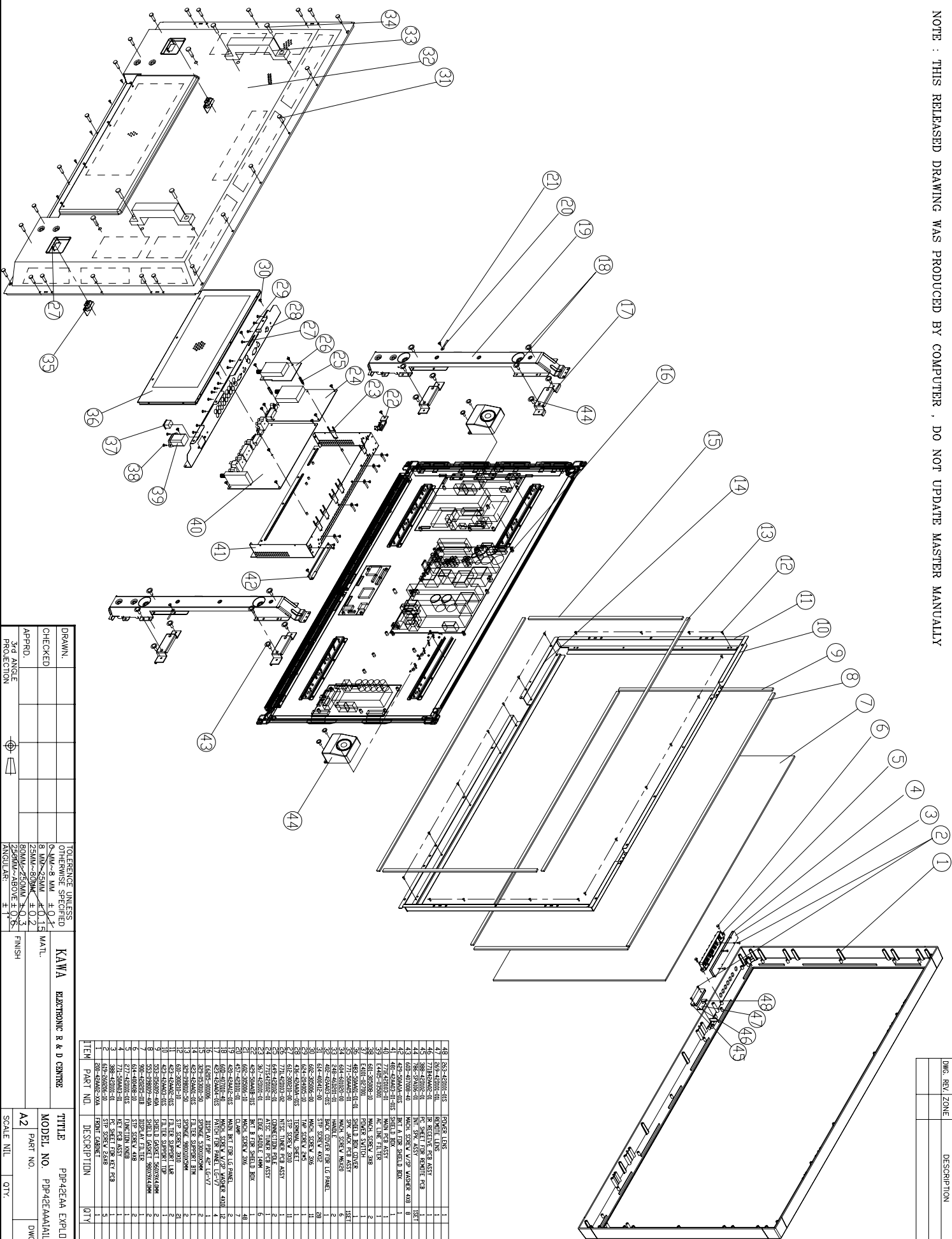

| DWG. REV. ZONE | DESCRIPTION | DATE | REVISOR |
|----------------|-------------|------|---------|
| | | | |
| | | | |
| | | | |

| ITEM NO. | PART NO. | DESCRIPTION | QTY. | REMARK |
|----------|----------------|---------------------------|------|--------|
| 40 | 405-28000-01 | FRONT LENS | 1 | |
| 41 | 388-42008-01 | FR. RECEIVE PCB ASSY | 1 | |
| 42 | 771-28000-01 | FR. SHIELD FOR FRONT PCB | 1 | |
| 43 | 405-40008-01 | MATCH SCREEN W/FP MIRROR | 8 | |
| 44 | 405-40008-02 | FRONT A FILTER SHIELD BOX | 1 | |
| 45 | 491-28000-01 | SIGNAL BVS | 1 | |
| 46 | 491-28000-02 | MPR. SCREEN | 2 | |
| 47 | 1400-27270 | SCREEN SWITCH | 1 | |
| 48 | 597-1400-27270 | SPR. LOCK PCB ASSY | 1 | |
| 1 | 405-40008-01 | MATCH SCREEN MIRROR | 6 | |
| 2 | 405-40008-02 | FRONT COVER FOR LG PANEL | 2 | |
| 3 | 614-40008-02 | SIP SCREEN MATZ | 28 | |
| 4 | 614-40008-03 | MATCH SCREEN 206 | 11 | |
| 5 | 614-40008-04 | TERMINAL SHEET | 1 | |
| 6 | 614-40008-05 | SIP SCREEN | 11 | |
| 7 | 614-40008-06 | FRONT COVER FOR ASSY | 1 | |
| 8 | 771-28000-02 | FRONT COVER FOR ASSY | 1 | |
| 9 | 771-28000-01 | FRONT COVER FOR ASSY | 1 | |
| 10 | 771-28000-01 | FRONT COVER FOR ASSY | 1 | |
| 11 | 771-28000-01 | FRONT COVER FOR ASSY | 1 | |
| 12 | 771-28000-01 | FRONT COVER FOR ASSY | 1 | |
| 13 | 771-28000-01 | FRONT COVER FOR ASSY | 1 | |
| 14 | 771-28000-01 | FRONT COVER FOR ASSY | 1 | |
| 15 | 771-28000-01 | FRONT COVER FOR ASSY | 1 | |
| 16 | 771-28000-01 | FRONT COVER FOR ASSY | 1 | |
| 17 | 771-28000-01 | FRONT COVER FOR ASSY | 1 | |
| 18 | 771-28000-01 | FRONT COVER FOR ASSY | 1 | |
| 19 | 771-28000-01 | FRONT COVER FOR ASSY | 1 | |
| 20 | 771-28000-01 | FRONT COVER FOR ASSY | 1 | |
| 21 | 771-28000-01 | FRONT COVER FOR ASSY | 1 | |
| 22 | 771-28000-01 | FRONT COVER FOR ASSY | 1 | |
| 23 | 771-28000-01 | FRONT COVER FOR ASSY | 1 | |
| 24 | 771-28000-01 | FRONT COVER FOR ASSY | 1 | |
| 25 | 771-28000-01 | FRONT COVER FOR ASSY | 1 | |
| 26 | 771-28000-01 | FRONT COVER FOR ASSY | 1 | |
| 27 | 771-28000-01 | FRONT COVER FOR ASSY | 1 | |
| 28 | 771-28000-01 | FRONT COVER FOR ASSY | 1 | |
| 29 | 771-28000-01 | FRONT COVER FOR ASSY | 1 | |
| 30 | 771-28000-01 | FRONT COVER FOR ASSY | 1 | |
| 31 | 771-28000-01 | FRONT COVER FOR ASSY | 1 | |
| 32 | 771-28000-01 | FRONT COVER FOR ASSY | 1 | |
| 33 | 771-28000-01 | FRONT COVER FOR ASSY | 1 | |
| 34 | 771-28000-01 | FRONT COVER FOR ASSY | 1 | |
| 35 | 771-28000-01 | FRONT COVER FOR ASSY | 1 | |
| 36 | 771-28000-01 | FRONT COVER FOR ASSY | 1 | |
| 37 | 771-28000-01 | FRONT COVER FOR ASSY | 1 | |
| 38 | 771-28000-01 | FRONT COVER FOR ASSY | 1 | |
| 39 | 771-28000-01 | FRONT COVER FOR ASSY | 1 | |
| 40 | 771-28000-01 | FRONT COVER FOR ASSY | 1 | |
| 41 | 771-28000-01 | FRONT COVER FOR ASSY | 1 | |
| 42 | 771-28000-01 | FRONT COVER FOR ASSY | 1 | |
| 43 | 771-28000-01 | FRONT COVER FOR ASSY | 1 | |
| 44 | 771-28000-01 | FRONT COVER FOR ASSY | 1 | |

| DRAWN. | CHECKED | APPROD. | 3rd ANGLE PROJECTION |
|--------|---------|---------|----------------------|
| | | | |
| | | | |

| ANGLE | FINISH | SCALE NIL | QTY. | SHEET 1 OF 1 |
|-------|--------|-----------|------|--------------|
| | | | | |
| | | | | |

TOLERANCE UNLESS OTHERWISE SPECIFIED
 3.0 ± 0.25
 25.0 ± 0.15
 25.0 ± 0.12
 25.0 ± 0.10
 25.0 ± 0.08
 25.0 ± 0.05

KAWA ELECTRONIC R & D CENTER

TITLE: PDP42EA EXPLODE VIEW
 MODEL NO. PDP42EAMAIL5-A01
 PART NO. A2
 DWG. NO.

If you forget your V-Chip Password

- Omnipotence V-Chip Password: 8202.

Using the “Change Password” item

- ❶ When enter the “V-Chip” menu, select “Change Password”.
- ❷ Press ▲ or ▼ button to highlight the “Change Password” item.
- ❸ Press **Enter** button to confirm and pop up a menu.

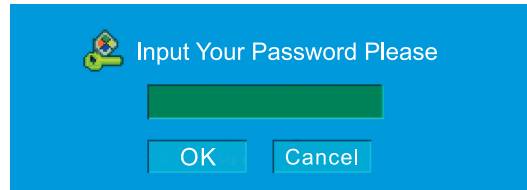

- ❹ Use 0~9 buttons input the omnipotence password(8202), then Press **Enter** button to enter and pop up a menu.

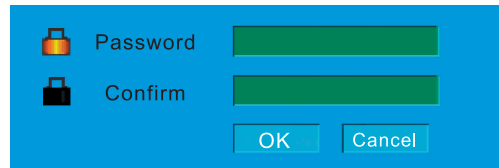

- ❺ Use 0~9 buttons input your new password.
- ❻ Press ▼ button to move to confirm blank.
- ❼ Use 0~9 buttons input your new password again.
- ❽ Press **Enter** button to confirm

-Suggest: Change to your familiar Password again.

Software Upgrade

Process of update MT8202

Preparing :

1. Connect **RS232-VGA download line**, One connector is connected to **VGA connect port of Plasma TV** ,while another side is connected to PC COM port.
2. Store the MtkTool into the PC .

Downloading :

3. Turn on AC power switch of the Plasma TV and then press the button “standby” of the remote control . The image could be found on the screen of the Plasma TV while the color of the power indicator is green . (the mode of the Plasma TV will be standby mode if after turn on the main power switch only .)
4. Execute MTKtool and select the chipset as MT8202. (the software of MTKtool will be sent to your side)

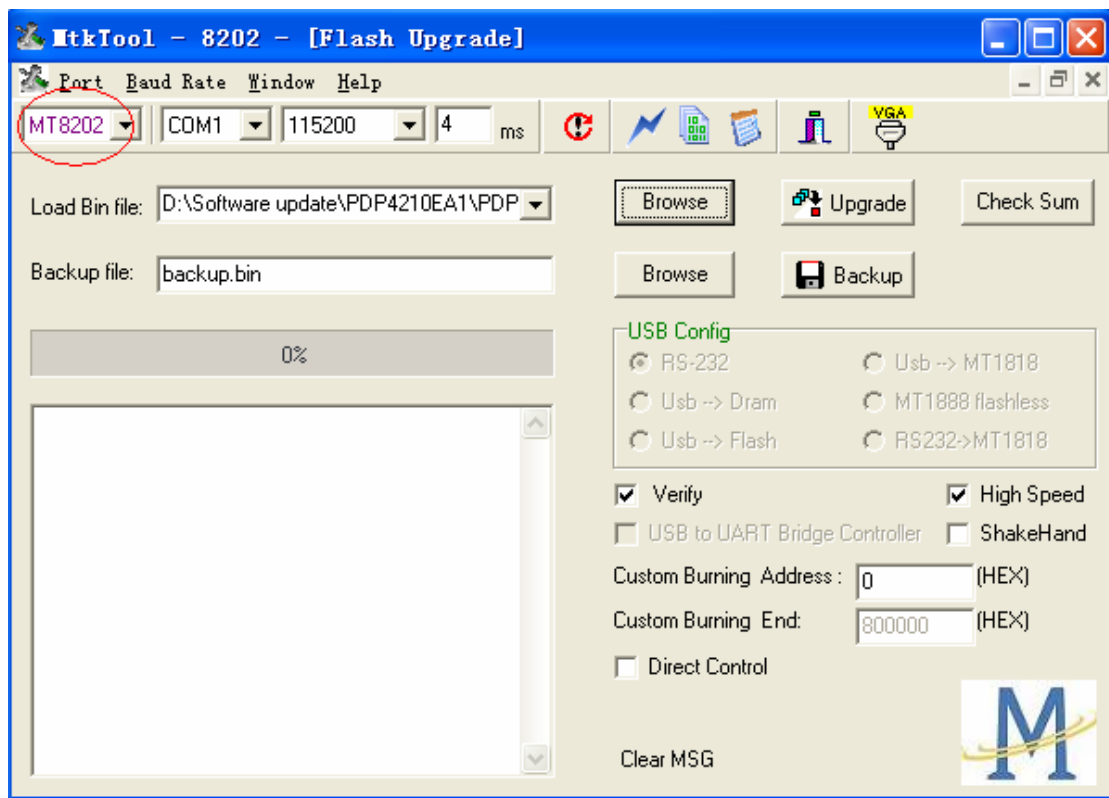

5. Select current COM port. (please try to check the COM port of your PC).

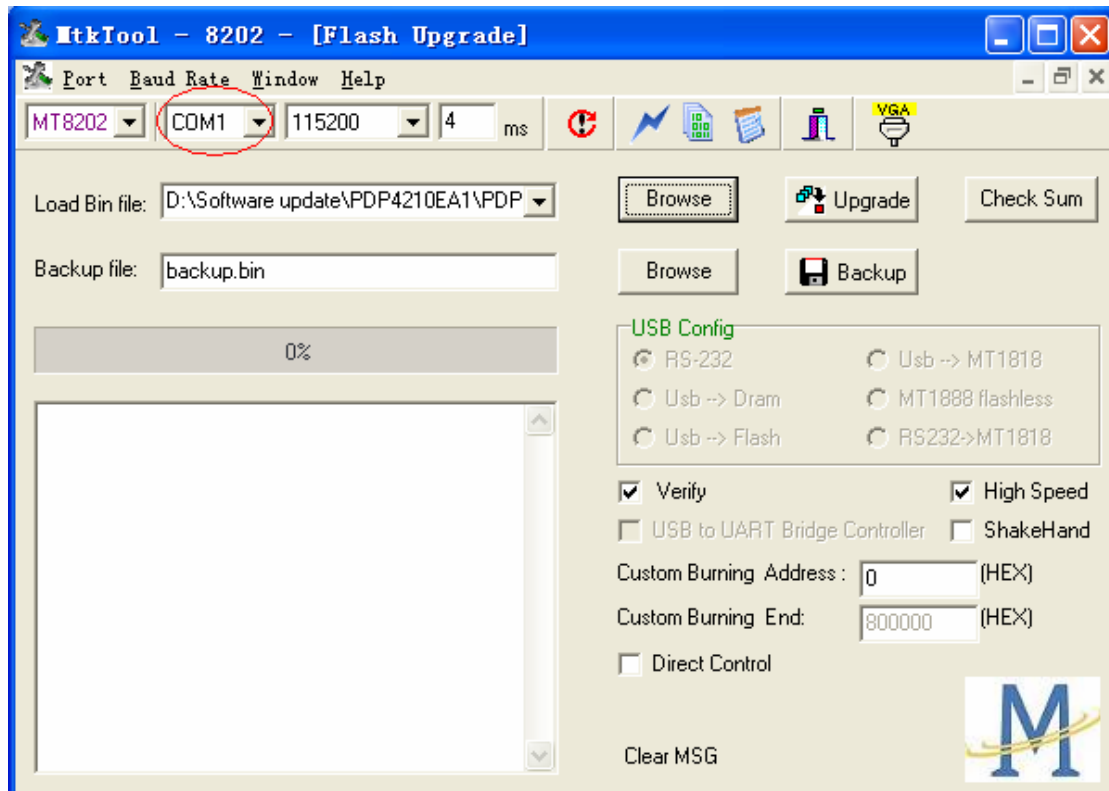

6. Choose the bit rate as 115200.
7. Select the update binary by pressing browse button. For example, the binary file name is PDP4210EA1_V09.bin. (this update firmware will be sent to your side)

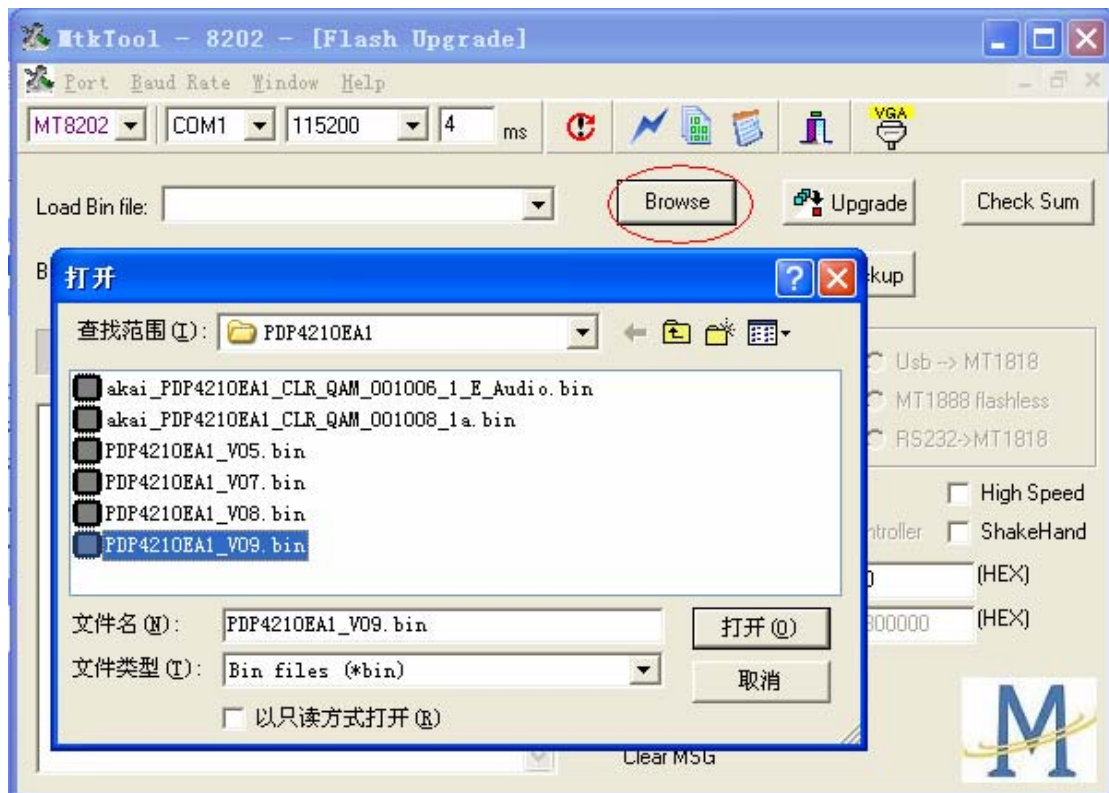

8. Press Upgrade button and start update process.

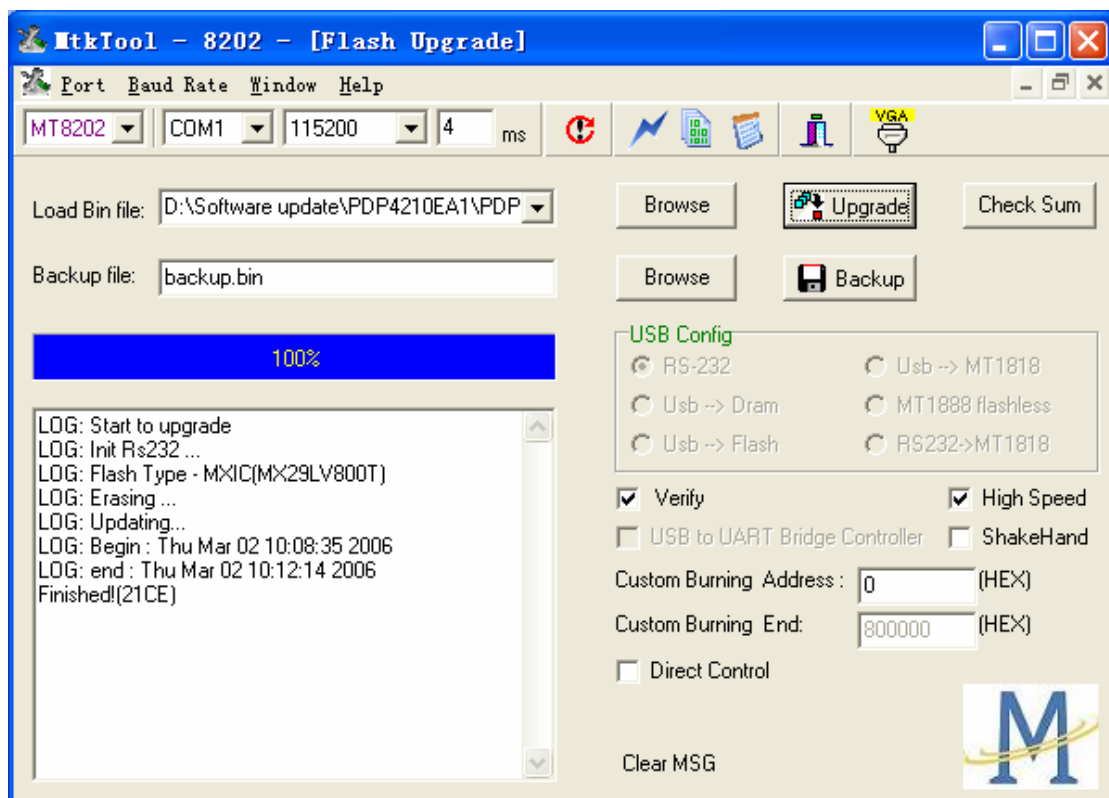
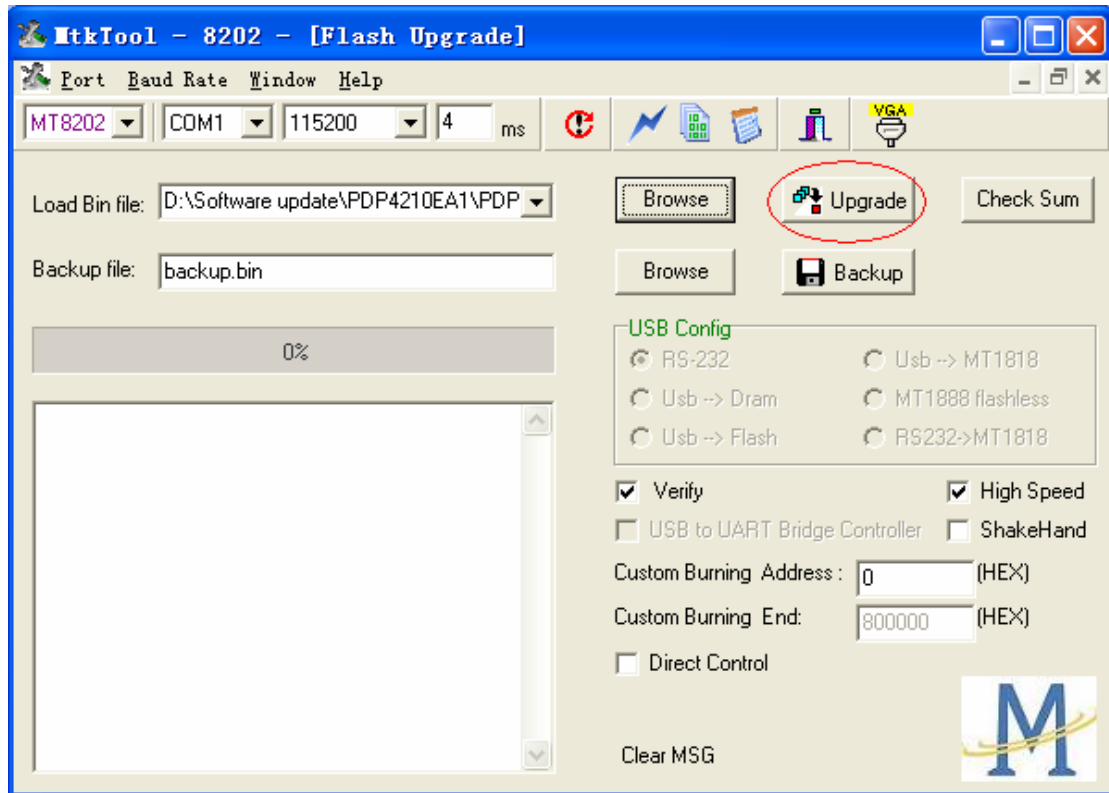

9. The update process is successful as the progress bar is 100%. After the update process is ok,

turn off power and wait indicator light is off. Turn on power and TV can work.

Checking

It is needed to check the version of the firmware for MT8202 which has been download into the Plasma TV .

Press Menu button of the remote control, following input “8202” of the remote control and OSD menu for Factory Setting is appeared on the screen .

Use the remote control and select the mode of Firmware Version and then enter the mode of Firmware Version . It is easy to be found the version of the current firmware for MT8202 is as the following : “Factory ID : PDP4210EA1_VXX ”

Process of update MT5351AG

Preparing :

1. Connect **RS232 download line**, One connector is connected to **RS232 connect port of Plasma TV** , while another side is connected to PC COM port.
2. Store the MtkTool into the PC

Downloading :

3. Turn on AC power switch of the Plasma TV and then press the button “standby” of the remote control . The image could be found on the screen of the Plasma TV while the color of the power indicator is green . (the mode of the Plasma TV will be standby mode if after turn on the main power switch only .)
4. Execute MTKtool and select the chipset as MT5351AG. (the software of MTKtool will be sent to your side)

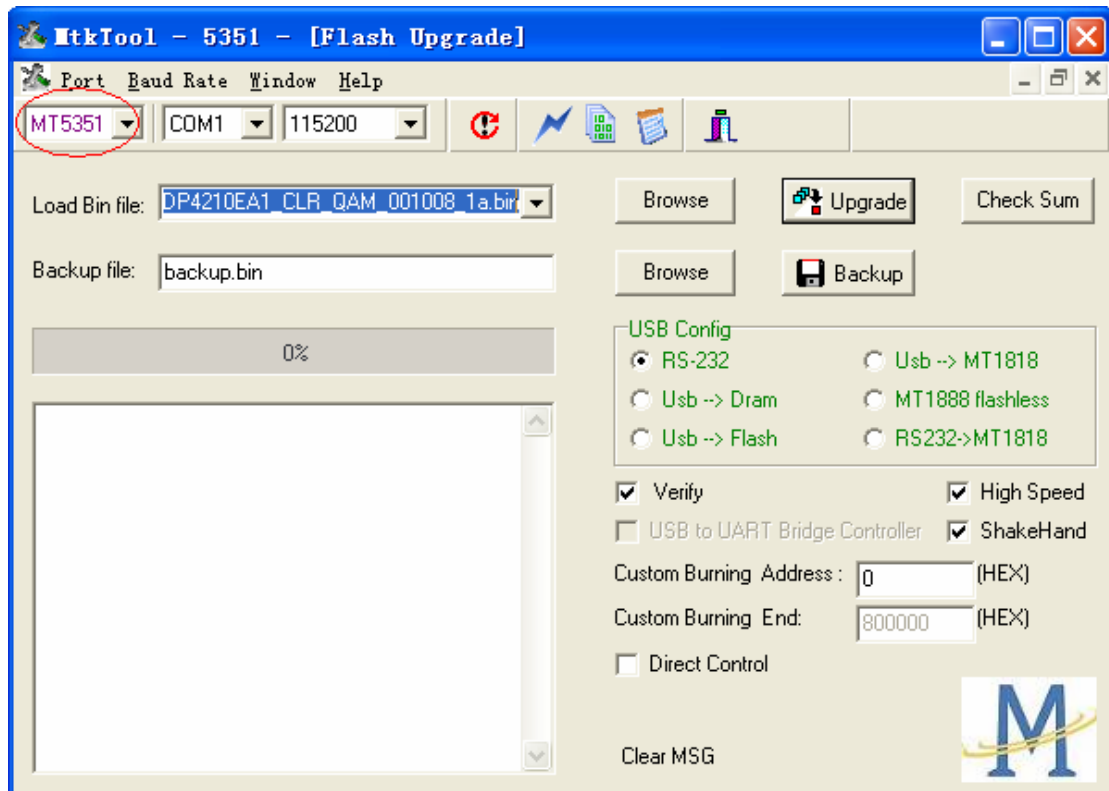

5. Select current COM port. (please try to check the COM port of your PC).

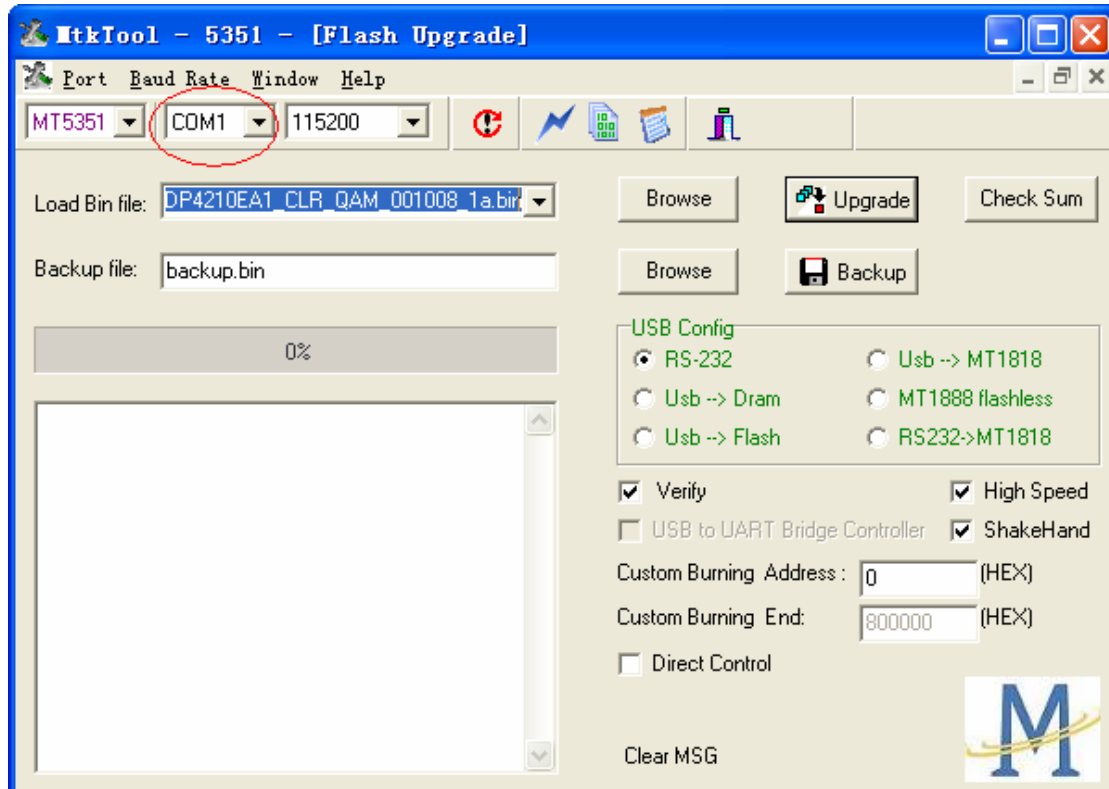

6. Choose the bit rate as 115200.

7. Select the update binary by pressing browse button. For example, the binary file name is

XXXX_PDP4210EA1_000000XX_X_P.bin. (this update firmware will be sent to your side)

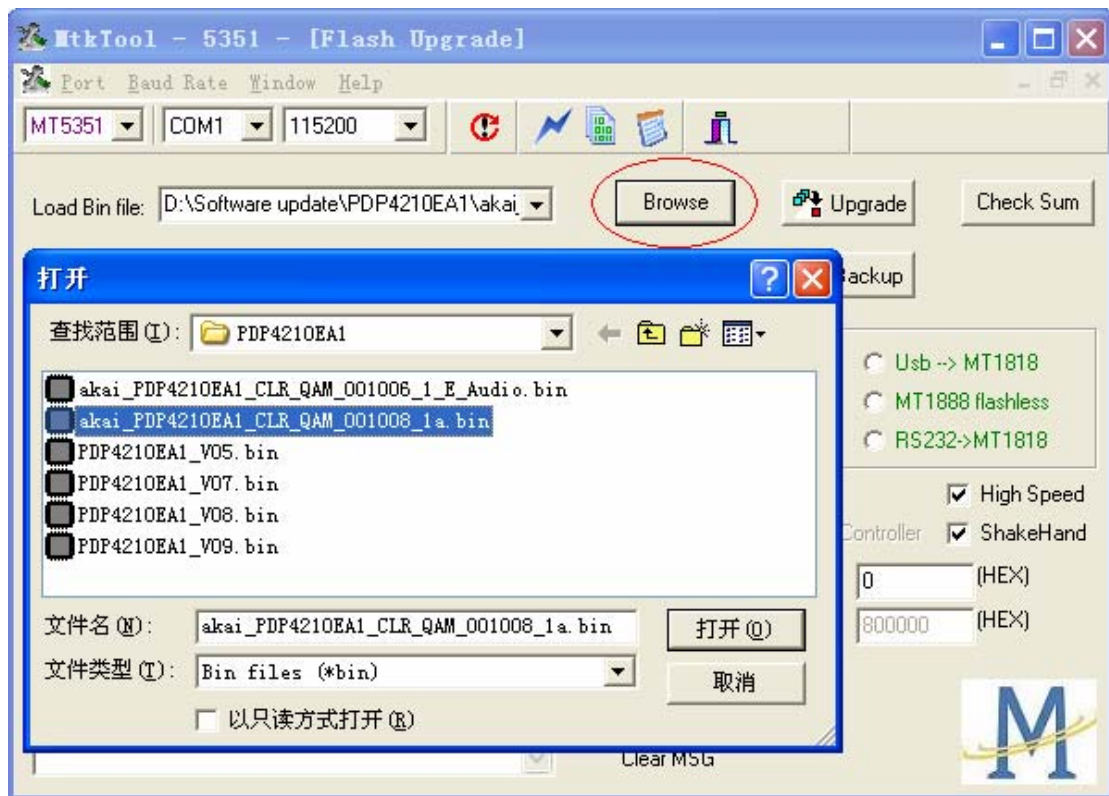

8. Press Upgrade button and start update process.

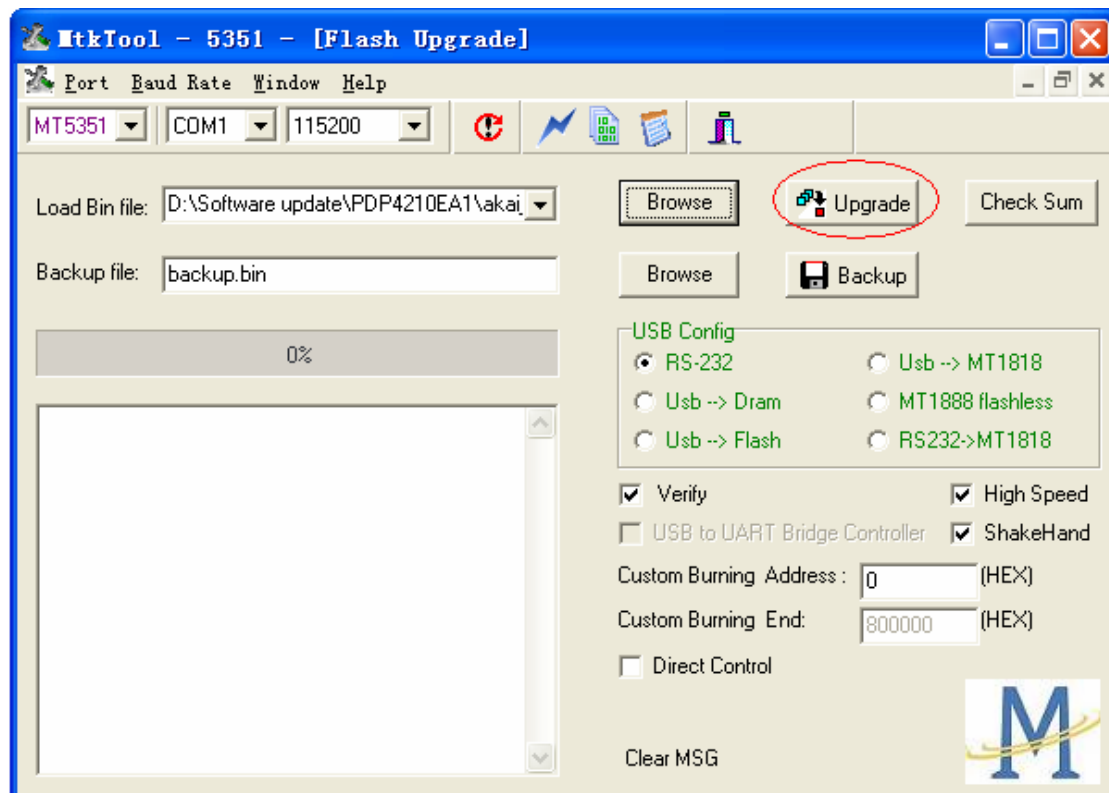

9. The update process is successful as the progress bar is 100%. After the update process is ok, turn off power and wait indicator light is off. Turn on power and TV can work.

Checking :

It is needed to check the version of the firmware for MT5351AG which has been download into the Plasma TV .

Press Menu button of the remote control and the main OSD menu is appeared on the screen .

Use the remote control and select the DTV menu . following input “0000” (zero , zero , zero , zero) of the remote control .Then enter the mode of factory after input the digits .

It is easy to be found the version of the current firmware for MT5351AG is “PDP4210EA1 CLA_QAM_XXXXXX_XX”under the mode of factory .

